

STANDARD BID SOLICITATION DOCUMENT

GOVERNMENT OF GUYANA



*Design, Supply, Installation and
Commissioning of an 88.6 kWp Off-Grid Solar
Photovoltaic Micro-Grid System and Electrical
Distribution Network in Sebai*

GUYANA ENERGY AGENCY

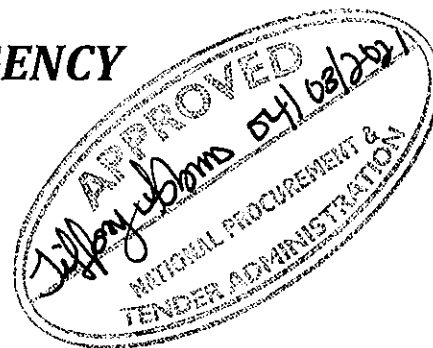

March 2021

GOODS AND RELATED SERVICES (VALUE G\$15 million and above)

Introduction

Preface

This Standard Bid Solicitation Document (SBSD) has been prepared by the National Procurement and Tender Administration Board (NPTAB) for use by Procuring Entities for the procurement of goods and services. The procedures and methods presented in this document have been developed on the basis of practical experience and are mandatory for use in the procurement carried out in whole or in part from the state funds in accordance with the provisions of Guyana's Public Procurement Legislation.

In order to simplify the preparation of the bid document for each individual procurement proceeding, the SBSB groups the provisions that are not intended to be changed in "the Instructions to Bidders" and in "the General Conditions of Contract". Data and provisions specific to each procurement and contract should be included in the Bid Data Sheet, the Special Conditions of the Contract, Technical specifications, price schedule, schedule of requirements and the Evaluation Criteria. The applicable forms are listed in the table of contents, below.

Request for additional information can be forwarded to:

The Guyana Energy Agency
Telephone number: 592-225-8569
gea@gea.gov.gy
www.gea.gov.gy

CONTENTS

Invitation for Bids (IFB)	3
Instructions to Bidders (ITB)	4
Bid Data Sheet (BDS)	10
General Conditions of Contract (GCC)	13
Special Conditions of Contract (SCC)	17
Delivery Schedule	20
Technical Specifications	22
Supplier's Bid	48
Price Schedule	50
Contract	57
Bid Security	58
Manufacturer's Authorization	59
Performance Security	60
Letter of Acceptance	61
Authorization for Signing the Bid	62
Evaluation and Qualification criteria	63
Pending Litigation Form	69

INVITATION FOR BIDS (IFB)

1. **The Guyana Energy Agency** hereinafter referred to as “the Procuring Entity”, invites eligible bidders to submit their bids for the **Design, Supply, Installation and Commissioning of an 88.6 kWp Off-Grid Solar Photovoltaic Micro-Grid System and Electrical Distribution Network in Sebai, as per the required specifications mentioned in the Bidding Documents, Region 1** as per the required specifications mentioned in the Bidding Documents.
2. Required period of supply: **Two hundred and ten (210) days from the signing of the Contract.**

Bidders are required to visit the site to carry out their own assessment of how the system will be installed. GEA would contact the entity and request access to the site by the bidders upon the bidder’s request. The costs of visiting the site shall be at the bidder’s own expense

3. The bidding documents may be obtained and be examined by any interested bidder. Bids can be purchased for a non-refundable fee in the amount of \$2,000 from the Cashier at the *Guyana Energy Agency, 295 Quamina Street, South Cummingsburg, Georgetown*, telephone 226-0394 or fax 226-5227, email at gea@gea.gov.gy.
4. All Bidders should submit their bids together with an original bid security of 2% of the tendered amount not later than 9:00 hours on the 6th day of April, 2021 at the: **National Procurement & Tender Administration Board, Ministry of Finance, 49 Main & Urquhart Streets, Georgetown.**

Clarifications must be submitted in writing to the GEA’s email address at gea@gea.gov.gy no later than one week prior to the deadline for bid submission.

5. Bids shall be valid for ninety (90) days after the date of bid opening.
6. Bids shall be opened by the National Procurement and Tender Administration Board in the presence of Bidders’ representatives who wish to attend, at 9:00 hours on the 6th day of April, 2021 at the address: 49 Main and Urquhart Streets, Georgetown.
7. All Bidders are advised to attend a pre-bid meeting to be held on the 26th day of March, 2021 at 13:00hours via zoom, details of which will be provided to all bidders by the procuring entity

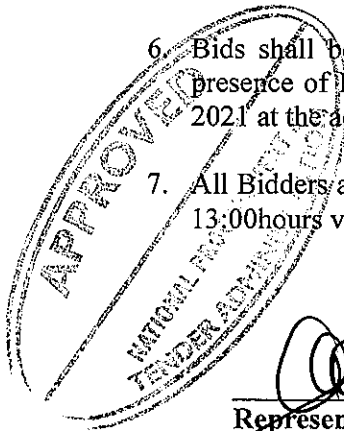

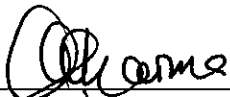
Representative of Procuring Entity

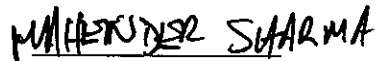
/Full name/

Guyana Energy Agency
Quamina St, S/Cummingsburg
Georgetown, Guyana.

INSTRUCTIONS TO BIDDERS

A. Introduction

1. Description of the Procurement

The Procuring Entity identified in the *Bid Data Sheet* intends to procure the goods identified in the *Bid Data Sheet* and in the Schedule of Requirements.

2. Eligibility and Qualifications of Bidders

- 2.1 In order to be awarded a procurement contract, Bidders should possess the technical and financial capacity needed to perform the contract, should fulfill their tax and social insurance fund liabilities in Guyana, should not currently be subject to a debarment penalty, and must comply with the specific eligibility and qualification requirements referred to in the *Bid Data Sheet and Evaluation Criteria*.
- 2.2 The bidders should not have conflicts of interest, including involvement in more than one bid in this proceeding, should not be associated nor have been associated in the past, directly or indirectly, with any agency or any of its representative(s), affiliate(s), that have been engaged by the Procuring Entity to provide consulting services at the preparation stage of the bidding documents, technical specifications and other documentation that are subject to be used in the procurement of goods which must be purchased in accordance with the Invitation for Bids. In cases when the indicated facts are discovered, the Bidder's bid shall be rejected.

B. Bidding Documents

3. Clarification and Amendment of Bidding Documents

- 3.1 The Procuring Entity, in not more than three (3) working days, will respond in writing or electronic mail to any request for clarification of the bidding documents to be received (in writing or electronic mail) not later than seven (7) days before the expiry of a deadline for submission of bids. At the same time, the Procuring Entity's response shall without identifying its source of the request, be distributed to all bidders who have received the bidding documents from the Procuring Entity.
- 3.2 At any time before the deadline for submission of bids, the Procuring Entity may amend the bid documents by issuing an Addendum to the bidders.

C. Preparation of Bid

4. Language of Bid

- 4.1 The bid prepared by the Bidder, as well as all correspondence and documents related to that bid and exchanged by the Bidder and the Procuring Entity shall be written in the language *specified in the Bid Data Sheet*.

5. Documents Included in Bid

- 5.1 The bid prepared by the Bidder should contain the Form of Bid, the Price Schedules and the other documents to be submitted in accordance with these Instructions to Bidders, Bid Data Sheet and Evaluation Criteria.

6. Bid Price

6.1. Subject to the choice of INCOTERMS as indicated in the Bid Data Sheet, the prices given in the Price Schedule shall include all transportation costs to the destination point indicated in the Contract, all taxes, duties, payments collected, in accordance with the laws of Guyana and delivery related and other costs on performing of contractual obligations.

6.2. The prices offered by the Bidders shall remain fixed during the whole period of Contract performance and shall not be modified in any circumstance.

7. Bid and Payment Currency

7.1 The prices shall be indicated in Guyana Dollars, unless otherwise specified in the *Bid Data Sheet*.

8. Bid Security

8.1 Unless otherwise provided in the *Bid Data Sheet*, the Bidder shall furnish, as part of his bid, an original Bid Security, in the form, currency and amount specified in the *Bid Data Sheet* with a validity period for not less than two (2) weeks upon the expiry of the bid validity period and in accordance with the specified form.

8.2 The bid security may be forfeited, if the Bidder:

(a) withdraws their bid after it is opened during the period of validity specified in the bid; or,

(b) having been awarded the contract fails:

(1) to sign the contract on the terms and conditions provided in their bid; or

(2) to furnish the Performance Security, if required to do so.

9. Period of Validity of Bid

9.1 Bids shall remain in force during the period specified in *the Bid Data Sheet* after the date of bid opening.

10. Format, Signing and Submission of Bid

10.1 The Bidder shall prepare an original bid which shall be completed in writing in indelible ink and shall be signed by the Bidder, or by the person (persons) duly authorized to sign the bid in accordance with the power of attorney and 2 (two) exact electronic PDF copies of the bid on Flash Drive, to be submitted with the bid. All pages of the bid where new information, modifications or erasures entered shall be initialed (signed) by the person or persons signing the bid. In the event of discrepancies between them, the original shall prevail.

10.2 The bid shall contain no interlineations, erasures or overwriting, except the cases when the Bidder needs to correct errors which must be initialed by the person or persons signing the bid.

10.3 The Bidder shall seal the original and Electronic PDF copies of the bid in different envelopes, marking them "ORIGINAL" and "COPIES", as appropriate. The envelopes shall then be sealed in an outer envelope.

10.4 The outer envelope shall:

- (a) be addressed to the **Chairman, National Procurement & Tender Administration Board (NPTAB), Main & Urquhart Streets, Georgetown** (the address specified in the Invitation for Bids);
- (b) **bear the Name of the Project (*Design, Supply, Installation and Commissioning of an 88.6 kWp Off-Grid Solar Photovoltaic Micro-Grid System and Electrical Distribution Network in Sebai*) and the words: "DO NOT OPEN BEFORE" 9:00 hours on the 6th day of April, 2021.**

11. Deadline for Submission of Bids

- 11.1 Bids must be received by the Procuring Entity at the address and within the periods specified in *the Bid Data Sheet*. All bids received by the Procuring Entity upon the expiry of a period established for submission of bids as indicated by the Procuring Entity shall be rejected and returned to the Bidder unopened.

12. Modification and Withdrawal of Bids

- 12.1 The Bidder may modify or withdraw their bid after the bid's submission, provided that the Procuring Entity will receive a written notice of modification, substitution or withdrawal of bid before the deadline for submission of bids.
- 12.2 The Bidder's modification, substitution or withdrawal notice shall be prepared, sealed, marked, and sent in accordance with the provisions of ITB Clause 10. In that case the outer and inner envelopes will be additionally marked as "**MODIFICATION**" or "**WITHDRAWAL**", as appropriate. A withdrawal notice may also be sent by email with a subsequent written confirmation not later than the deadline for submission of bids.

D. Opening and Evaluation of Bids

13. Opening of Bids

- 13.1 The Procuring Entity will open all bids in the presence of bidders' representatives who wish to attend, at the time, on the date, and at the address specified in the *Bid Data Sheet*. The bidders' representatives who are present shall sign a register evidencing their attendance.
- 13.2 The bidders' names, bid prices, including alternatives (if permitted), information on the presence or absence of required bid security, information on the presence (absence) of tax debts and debts of social insurance payments will be announced at the opening. No bid shall be rejected at the opening, exclusive of late bids and unidentified Bids to be returned to the Bidder unopened.
- 13.3 Bids and modifications sent pursuant to ITB Clause 12.2 that are not opened and read out during the bid opening shall not be accepted for further evaluation, regardless of circumstances.

14. Evaluation of Bids

- 14.1 During the evaluation of bids, the Procuring Entity may, at its discretion, request the Bidder to provide clarification of their bid. The request for clarification and the response thereto shall be made in writing, and in that case no change in price or substance of the bid shall be sought, offered, or permitted.
- 14.2 The Procuring Entity shall determine the responsiveness of each bid to requirements of the bidding

documents. For the purposes of this Clause a substantially responsive bid is one which satisfies all the indicated provisions without a material deviation or reservation.

- 14.3 The Procuring Entity may regard a tender as responsive if it contains any minor deviations, that do not materially alter or depart from the characteristics, terms and conditions and other requirements of the bid solicitation documents, or if it contains errors or oversights that are capable of being corrected without touching the substance of the tender. To the extent feasible and appropriate, for the purposes of comparing bids, acceptable deviations shall be quantified in monetary terms, and reflected in adjustments to the bid price (for the purposes only of comparison of bids).
- 14.4 Arithmetical errors shall be rectified in the following manner. If there is a discrepancy between the unit price and the total price that is obtained by multiplying the unit price and quantity, the unit price shall prevail, and the total price shall be corrected. If there is a discrepancy between words and figures, the amount in words shall prevail. If the Bidder disagrees with such correction of errors, their bid shall be rejected.
- 14.5 The Procuring Entity shall evaluate and compare only the bids that are determined to be responsive to the Bid Solicitation Document.

15. Confidentiality and Contacting the Procuring Entity

- 15.1 No Bidder shall contact the Procuring Entity on any matter related to their bid from the date of bid opening until the date of contract award, except for requests related to clarification of the bid. Information concerning the evaluation of bids is confidential.
- 15.2 Any effort by the Bidder to influence the Procuring Entity's decision on bid evaluation and comparison, or contract award may result in the rejection of that Bidder's bid and subjected to debarment in accordance with Regulation 3(1)(b) of the Procurement (suspension and debarment) Regulations 2019.

E. Award of Contract

16. Award Criteria

- 16.1 Subject to ITB Clause 18, the Procuring Entity will award the Contract to the Bidder whose bid is determined to be substantially responsive to the requirements of the bid solicitation document, and who offered **the Lowest Evaluated Bid**, provided that the Bidder has been determined:
- (a) to be eligible pursuant to Clause 2;
 - (b) to comply with qualification requirements, in accordance with Clause 2, and any technical requirements and evaluation criteria disclosed in the bid solicitation documents.

17. Procuring Entity's Right to Vary Quantities at Time of Entering into a Contract

- 17.1 The Procuring Entity reserves the right, when entering into a contract, to increase or decrease the quantity of goods and related services specified in the Schedule of Requirements, by the percentage indicated in the *Bid Data Sheet*, no change in the unit price or other conditions shall be made (an increase of quantity **not exceeding 10 percent variation**)

18. Procuring Entity's Right to Accept Any Bid and to Reject All Bids

- 18.1 The Procuring Entity reserves the right to accept or reject any bid or all bids, and to cancel the

bidding process at any time prior to award of contract, without thereby incurring any liability to Bidders and without being required to inform the Bidder or Bidders of reasons of such actions.

19. Notification of Award

- 19.1. The bidder whose bid is accepted will be notified of the award of contract by the Purchaser prior to expiration of the bid validity period.
- 19.2. The notice of acceptance shall be given to the successful bidder within fourteen (14) days of the award of contract.
- 19.3. At the same time that the Procuring Entity notifies the successful Bidder in accordance with sub-clause (1), the Procuring Entity will notify all other Bidders of the name of successful Bidder, and their bid price.

20. Signing of Contract and Performance Security

- 20.1 The Procuring Entity will send the successful Bidder the Form of Contract contained in the bid solicitation document. The successful Bidder shall sign and date the Contract and return it to the Procuring Entity within seven (7) days of receipt of notice of award.
- 20.2 Together with the signed Contract, the Bidder shall, if required to do so by the *Bid Data Sheet*, furnish the Procuring Entity with a Performance Security in the amount and form specified in the *Bid Data Sheet*.
- 20.3 If the successful Bidder fails to furnish the performance security, if required to do so, or within 7 (seven) days fails to return the Contract signed by them, then it shall be a sufficient ground to refuse the award of Contract, and to forfeit the bid security. In that case the Procuring Entity shall award the Contract to the next lowest evaluated Bidder, subject to the right of the Procuring Entity to reject all bids.

21. Settlement of Disputes

- 21.1 To settle the disputes which may arise during the execution of Contract, the parties shall follow the procedure referred to in the *Bid Data Sheet*.

22. Corrupt and Fraudulent Practices

- 22.1 The Procuring Entity requires that Bidders observe the highest standards of ethics during the bidding process and execution of such contracts. In pursuance of this policy, the Procuring Entity:
 - (a) will reject the bid if it establishes that the Bidder recommended for award has engaged in corrupt, fraudulent, collusive, or coercive practices in competing for the Contract in question.
 - (b) refer the matter to the Public Procurement Commission (PPC) in accordance with the provisions of Procurement (Suspension and Debarment) Regulations 2019.

23. Compliances

- 23.1 Bidder must submit valid certificates of compliances from Guyana Revenue Authority (GRA), National Insurance Scheme (NIS), and VAT registration (*where applicable*).

24. Defects Liability:

- 24.1 The “Defects Liability Period” for the goods and related services is six (6) months from the date of taking over possession or such other period as may be specified in the Bid Data Sheet. During this period, the supplier will be responsible for rectifying any defects or replacement of goods free of cost to the Procuring Entity.

Bid Data Sheet (BDS)

The following specific data to clauses of the provisions of Instructions to Bidders which supplement or amend the provisions of the Instructions to Bidders (ITB). Whenever there is a conflict, the provisions herein shall prevail over those in ITB.

Item No.	
ITB 1.1	<p>Guyana Energy Agency, 295 Quamina Street, South Cummingsburg, Georgetown, tel:226-0394, gea@gea.gov.gy.</p> <p>The subject of the procurement is: <i>Design, Supply, Installation and Commissioning of an 88.6 kWp Off-Grid Solar Photovoltaic Micro-Grid System and Electrical Distribution Network in Sebai as follows:</i></p> <p>Lot 1: <i>Design, Supply, Installation and Commissioning of an 88.6 kWp Off-Grid Solar Photovoltaic Micro-Grid System in Sebai</i></p> <p>Lot 2: <i>Design, Supply & Construction of a 4 km Overhead Electrical Distribution Network at Sebai</i></p>
ITB 2.1	<p>To qualify for award of the Contract, the bidders shall meet the qualification requirements set out in the evaluation criteria</p>
ITB 4.1	<p>Language of Bid shall be English Language All submission must be in English or translated to English if different. Such translations must be signed and stamped by a registered translator or embassy or consulate</p>
ITB 5.1	<p>The Bidder shall submit the following additional documents in its bid:</p> <ol style="list-style-type: none"> 1. Evidence of Financial Capability in the amount of 30% of the bid price in the form of a bank statement as at January 2021 or letter of credit from a commercial bank in the name of the bidder. Letter of credit must state a figure. The document must be dated within one month of the bid opening date and be clearly legible. When a photocopy of the letter of credit or bank statement is presented, it must be certified a "true copy of the original" by the issuing company. 2. Submission of a valid business registration or certificate of incorporation, inclusive of list of directors, that is clearly legible. Where bidder is part of an unincorporated joint venture, a legible copy of joint venture agreement is required. Copy of joint venture agreement must state the joint venture partner to which invoice will be paid and contract to be signed. Where bidder is a joint venture company, a legible copy of certificate of incorporation is to be submitted. Each party must submit valid compliance as per items 2 and 3 of the Evaluation Criteria. 3. Written confirmation of authorizing signatory must be provided. For the incorporated company this must be in the form of a Power of Attorney endorsed by a Commissioner of Oaths or Justice of Peace. For a registered business that has appointed an employee to sign the bid, a letter of authorizing signatory must be provided. 4. Valid certificates of compliance from GRA and NIS and VAT registration (only applicable to Bidders resident in the country of the Procuring Entity). 5. Completed litigation form on page 69 of the bidding documents. 6. A letter stating any or no termination or abandonment of projects. The letter must be dated within one month of the bid opening date. Provide documentary evidence that the goods are ISO certified and Tropic resistant; 8. Provide documentary evidence that the PV modules comply with IEC 61215 & IEC 62804 for Crystalline Silicon PV Modules (or equivalent) standards, and that the inverters are UL 1741 listed; 9. Provide documentary evidence to demonstrate that the Goods offered meet all the technical

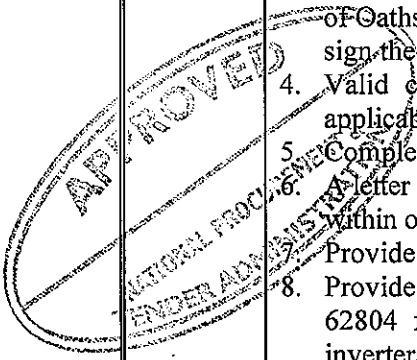

	<p>specifications of the bidding document. Technical literature must include data sheets and specific technical information on each of the items of equipment and components proposed for the photovoltaic system;</p> <p>10. A detailed schematic design layout for the solar PV system and distribution network (schematic should be NEC 2017 Compliant), including explanatory notes for sizing of equipment and components that comprise the system, and energy production calculations using a PV modelling software;</p> <p>11. Certificates of product quality (modules and inverters) issued by a recognized laboratory accredited by the International Laboratory Accreditation Cooperation (ILAC) and which must be valid up to the date of commissioning of the system;</p> <p>12. Documentary evidence that batteries comply with IEC 61427:1999 and the manufacturing process conformed to environmental management standard ISO 14001</p> <p>13. Provide documentary evidence that the pad mounted transformer complies with IEEE Std C57.12.28, IEEE Std C57.12.3</p> <p>14. Provide documentary evidence that the pole mounted transformers comply with IEEE Std C57.12.20-2017</p> <p>15. An implementation schedule indicating important milestones such as equipment delivery to site, installation, testing and commissioning. Frequent progress reports and work plan are to be provided to the Procuring Entity as required by the procuring entity during project execution.</p> <p>16. Bidder must provide audited financial statements for the past three years for incorporated companies. Financial statements must be audited by a Chartered accountant/accountancy firm and include an auditor's note.</p> <p>OR</p> <p>Registered businesses must provide Balance Sheets, Profit and Loss Accounts, and Income and Expenditure Accounts for the past three years. These financial statements must be approved by a Chartered accountant/accountancy firm.</p> <p>The detailed evaluation criteria can be found on Page 63 of the bidding documents</p>
ITB 6.1	The price quoted by bidders shall be on the basis of CIF to port Georgetown for goods delivered to Guyana, including cost for transport to the site. 2010 incoterms are applicable.
ITB 7.1	Currency of Bid shall be in Guyana Dollars.
ITB 8.1	A bid security of two percent (2%) of the tendered sum is required in the form of a Bank guarantee or a bond from an Insurance company licensed by the Bank of Guyana.
ITB 9.1	The period of validity of bid is ninety (90) days
ITB 11.1	Deadline and place for submission of bids: 9:00 hours on the 6 th day of April, 2021 at <i>The National Procurement & Tender Administration Board, Ministry of Finance, Main & Urquhart Streets, Georgetown, Guyana</i>
ITB 13.1	Time and place for opening of bid: 9:00 hours on April 6, 2021 at <i>The National Procurement & Tender Administration Board, Ministry of Finance, Main & Urquhart Streets, Georgetown, Guyana.</i>
ITB 17.1	Increase or decrease in the quantity of goods and services not exceeding 10%
ITB 20.2	The amount of the performance security is 10% of the contract price. Performance Security must be in the form of a Bank Guarantee or a bond from an Insurance company licensed by the Bank of Guyana. This shall be valid for the duration of the contract period.
ITB 21.1	Disputes that may arise in the performance of the contract shall be settled in accordance with the applicable Laws of Guyana.

ITB 24.1	The duration of the defect's liability period is six (6) months following provisional acceptance.
-----------------	---

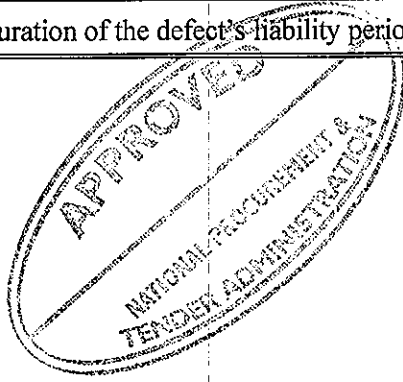

General Conditions of Contract (GCC)

The General Conditions are the Standard General Conditions of Contract. No alteration shall be made on the pages of these Conditions. The Procuring Entity, when amending or supplementing the General Conditions of Contract should do so only in the Special Conditions of Contract. Any amendment or addenda of the General Conditions of Contract shall conform to the legislation of Guyana.

1. Definitions and application

1.1 This Contract lists below the terms that have the following interpretation:

- (a) **“Contract”** means the agreement entered into between the Procuring Entity and the Supplier, as recorded in the Form of Contract signed by the parties, including all attachments and appendices thereto and all the documents referenced therein.
- (b) **“Contract Price”** means the price payable to the Supplier under the Contract for complete and proper performance of his contractual obligations.
- (c) **“Goods”** means the item (s) referred to in the Schedule of Requirements contained in the Bid Solicitation Document.
- (d) **“GCC”** means the General Conditions of Contract contained in this Section.
- (e) **“SCC”** means the Special Conditions of Contract.
- (f) **“Procuring Entity”** – means the Procuring entity carrying out the procurement of Goods, specified in the SCC.
- (g) **“Supplier”** means an individual or legal entity, or a combination of any abovementioned forms which operate under the existing agreement as a joint venture and supply the Goods and Services under the Contract.
- (h) **“Day”** means calendar day.

1.2 The General Conditions of Contract shall apply in the procurement of goods; the specific amendment, addition and alteration shall be indicated in the Special Conditions of Contract.

1.3 Warranty requirements are as specified in the Special Conditions of Contract.

2. Contract Documents

2.1 Subject to the order of precedence set forth in the Contract Agreement, all documents forming the Contract (and all parts thereof) are intended to be correlative, complementary, and mutually explanatory. The contract shall be read as a whole.

3. Performance Security

3.1 If required by the SCC, within seven (7) days of receipt of notification of award, the successful Bidder shall furnish the Procuring Entity with the performance security the amount and form of which are indicated in the SCC.

4. Packing

4.1 The Supplier shall provide such packing of the Goods as is required to prevent their damage or deterioration during transit to final destination specified in the Contract, and as may be required by the Special Conditions of Contract.

5. Delivery, Transportation, Mobilization Advance

5.1 The Supplier must deliver the Goods within the periods and to the Destination point indicated in the Schedule of Requirements and shall provide the documentation indicated in the SCC. Subject to the SCC, transportation of the Goods to the place specified by the Procuring Entity shall be carried out and paid by the Supplier and related costs shall be included in the Contract Price.

6. Payment

6.1 The payment to the Supplier for the Goods delivered shall be made in accordance with the Contract in the form and within the periods specified in the SCC.

6.2 If the Procuring Entity does not pay the Supplier the sum due within the periods specified in the Contract, in that case the Procuring Entity shall pay the Supplier [interest at the rate specified or determined pursuant to the Special Conditions of Contract].

7. Prices

7.1 Prices established by the Supplier in the Contract for goods delivered shall not vary from the prices quoted by the Supplier in his bid.

8. Assignment

8.1 The Supplier shall not assign, in whole or in part, his obligations under the Contract to a third party for the execution without the Procuring Entity's prior written consent.

9. Delays in the Supplier's Performance and Liquidated Damages

9.1 Delivery of the Goods shall be carried out by the Supplier, in accordance with the schedule indicated by the Procuring Entity in the *Schedule of Requirements*.

9.2 Except as provided under GCC Clause 13, any delay in the Supplier's performance of their delivery obligations shall render the Supplier liable for payment of liquidated damages in the amount specified in the SCC, unless an extension of time is agreed upon by the parties without application of liquidated damages. Once the maximum deduction specified in the SCC is reached, the Procuring Entity may consider termination of the Contract, in accordance with Clause 10 of the General Conditions of Contract.

10. Termination

10.1 The Procuring Entity, without detriment to any other sanctions of infringement of the provisions of Contract, by written notice of default sent to the Supplier, may terminate this Contract in whole or in part:

- (a) if the Supplier fails to deliver a portion or all of the Goods within the periods provided for in the Contract, or within an extension period of that Contract, or to perform any of his obligations under the Contract.

- (b) if bankruptcy procedures are applied to the Supplier, or it is declared insolvent.
- (c) if the Supplier, in the Procuring Entity's opinion, has engaged in corrupt, fraudulent, collusive or coercive practices when entering into or executing the Contract.
- (d) If the Procuring Entity deems that continued implementation of the contract would no longer be expedient from the standpoint of the public interest.

10.2 The notice of termination shall specify the reason of termination, the extent to which performance of the Supplier under the Contract is terminated, and the date upon which such termination becomes effective.

10.3 Notwithstanding clauses 9 and 10.1(d), the Supplier shall not forfeit their performance security, and shall not be liable for payment of liquidated damages, or termination for default, if delay in executing the Contract or failure to perform obligations under the Contract is the result of an event of force majeure. When force majeure arises, the Supplier shall promptly notify the Procuring Entity in writing of such circumstance and its causes.

10.4 When the contract is terminated in accordance with clause 10.1(d), the Goods that are complete and ready for shipment within twenty-eight (28) days after the Supplier's receipt of notice of termination shall be accepted by the Procuring Entity at the Contract terms and prices. For the remaining Goods, the Procuring Entity may elect:

- (a) to have any portion completed and delivered at the Contract terms and prices; and/or
- (b) to cancel the remainder and pay to the Supplier an agreed amount for partially completed Goods and Related Services and for materials and parts previously procured by the Supplier.

11. Settlement of Disputes

11.1 If any dispute or disagreement arises between the Procuring Entity and the Supplier for the Contract or in connection with it, the parties shall make every effort to resolve the dispute or disagreement amicably by mutual consultation.

11.2 If during twenty one (21) days, the parties failed to resolve their dispute or disagreement by mutual consultation; either the Procuring Entity or the Supplier may send the other party the notice of intent to commence arbitration, if an arbitration is incorporated in the Contract in the Special Conditions of Contract or otherwise agreed by the parties, or in the Court of General Jurisdiction if no arbitration is envisaged, and no arbitration or litigation in respect of that matter may be commenced unless such notice is given.

Any dispute or disagreement in respect of which the notice of intent is sent to commence trial shall be heard by the [Court of General Jurisdiction].

11.3 Notwithstanding any reference to dispute settlement herein, the parties shall continue to perform their obligations under the Contract, unless they agree otherwise.

12. Applicable Law

12.1 The Contract shall be interpreted in accordance with the Laws of Guyana.

13. Formal Communication between the Procuring Entity and the Supplier

13.1 Any notice given by one party to the other pursuant to the Contract shall be in force if it is done in writing and sent at the address of other party in the SCC.

13.2 A notice shall be effective when delivered or on the specified date, whichever is later.

14. Taxes and Duties

14.1 The Supplier shall be fully responsible for all taxes, duties, license taxes, etc., levied in accordance with the legislation of Guyana, and subject to the application of INCOTERMS in accordance with the SCC.

15. Retention

15.1 No retention shall be applied on consumables, but warranties, guarantees and expiry dates to apply.

15.2 Retention on fixed assets shall be determined by the Procuring Entity on a case-by-case basis.

Special Conditions of Contract (SCC)

The following Special Conditions of Contract shall supplement the General Conditions of Contract. Whenever there is a conflict, the provisions herein shall prevail over those in the General Conditions of Contract.

GCC Clause No.	Special Conditions of Contract
1.1	<p>Definitions</p> <p>The Procuring Entity is the Guyana Energy Agency, 295 Quamina Street, South Cummingsburg, Georgetown, tel:226-0394, Fax:226-5227, gea@gea.gov.gy.</p> <p>The Supplier is _____ (indicate full name, legal address, phone, fax and e-mail of Supplier)</p> <p>The Subject of procurement is: <i>Design, Supply, Installation and Commissioning of an 88.6 kWp Off-Grid Solar Photovoltaic Micro-Grid System and Electrical Distribution Network in Sebai</i></p> <p>Warranty</p> <p>The supplier warrants all Goods supplied under the contract are new, unused, and of the most recent or current models, and that they incorporate all recent improvements in design and materials, unless provided otherwise in the contract. The supplier further warrants that all Goods supplied under this contract shall have no defect, arising from design, materials or workmanship or from any act or omission of the supplier, that may develop under normal use of the supplied Goods in the conditions prevailing in the country of final destination.</p> <p>24 months complete system warranty is applicable from provisional acceptance date. A final completion certificate shall be issued upon satisfactory commissioning of the systems.</p>
3.1	<p>Performance Security</p> <p>The amount and form of Performance Security is: 10% of the contract price in the form of a Bank Guarantee or a bond from an Insurance company licensed by the Bank of Guyana. The bond shall be valid for the entirety of the contract period.</p>
4.1	<p>Packing:</p> <p>The Supplier shall provide such packing of the Goods as is required to prevent damage or deterioration during transit to final destination, as indicated in the Contract. The packing shall be sufficient to withstand, without limitation, rough handling during transit and exposure to extreme temperatures, salt and precipitation during transit.</p>
5.1	<p>Delivery, Transportation</p> <p>The following documentation is to be provided by the Supplier to the Procuring Entity:</p> <ol style="list-style-type: none"> (1) Copies of Supplier's invoice indicating a description, quantity, unit price of the Goods and sum total. (2) shipping order, railway receipt or truck receipt. (3) Warranty certificate of Manufacturer or Supplier;

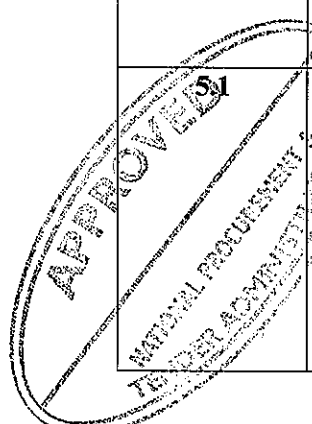

	<p>(4) Inspection certificate issued by the authorized inspection service, and the supplier's factory inspection report (if any); (5) Certificate of origin; (6) Certificate of conformity (7) Certificate of Quality</p>
<p>6.1</p>	<p>Payment schedule</p> <p>Lot 1 - (Design, Supply, Installation and Commissioning of an 88.6 kWp Off-Grid Solar Photovoltaic Micro-Grid as per Price Schedule below)</p> <p>(a) Ten percent (10%) of the contract price within 14 days of signing the contract and the submission of the performance bond.</p> <p>(b) Fifty percent (50%) of the contract price upon physical verification by the procuring entity that major components such as PV panel mount structure, PV modules, inverters and batteries have been installed by the supplier and have complied with the technical specifications.</p> <p>(c) Thirty percent (30%) of the contract price upon acceptance of the system by the procuring entity.</p> <p>(d) Ten percent (10%) of the contract price upon expiry of the defects liability period barring the correction of defects.</p> <p>Lot 2 - (Design, Supply & Construction of a 4 km Overhead Electrical Distribution Network at Sebai as per Price Schedule below)</p> <p>(a) Ten percent (10%) of the contract price within 14 days of signing the contract and the submission of the performance bond.</p> <p>(b) Fifty percent (50%) of the contract price upon physical verification by the procuring entity that major components such as the Pad mounted transformer, pole mounted transformers, line hardware and poles have been installed by the supplier and have complied with the technical specifications.</p> <p>(c) Thirty percent (30%) of the contract price upon acceptance of the system by the procuring entity.</p> <p>(d) Ten percent (10%) of the contract price upon expiry of the defects liability period barring the correction of defects.</p> <p>Withholding tax deductions shall be as follows:</p> <p>(a) For resident contractors: Each payment of G\$500,000 and above shall be subject to a withholding tax of 2% on every payment. The GEA shall provide the contractor with a certificate/statement of the gross amount of the payment received and the amount of tax deducted.</p> <p>(b) For non-resident contractors: Withholding tax shall be deducted at a rate of 20% on gross earnings, except for contractors from Canada, United Kingdom and CARICOM which have the Double Taxation Relief Order with Guyana. In such cases, the relevant rates of withholding taxes are applicable.</p>

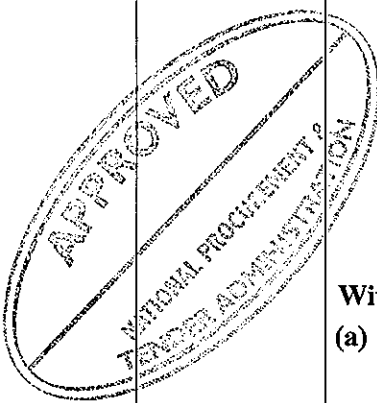

9.2	Liquidated Damages Applicable rate: 0.05% for untimely execution of order. Maximum deduction: 10% of the delayed works/delivery
11.2	Settlement of Disputes Disputes arising out of or in connection with the Contract shall be settled in accordance with the Laws of Guyana.
14.1	Taxes and Duties The version edition of INCOTERMS shall be: 2010

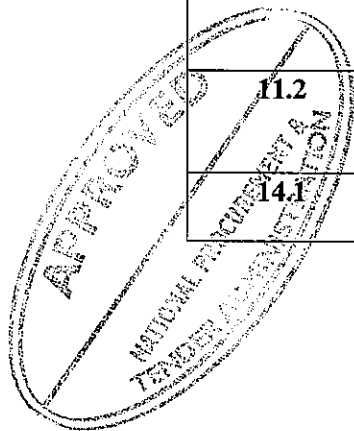

Delivery Schedule/ Schedule of Requirements

The delivery schedule expressed as days specifies hereafter the date of delivery to destination point. In column "the delivery schedule", the Procuring Entity shall indicate the date from which schedule starts. It should be either the date of award, or the date of signing of Contract, or the date of opening of letter of credit, or the date of confirming the letter of credit (subject to circumstances). The Form of Bid shall specify only reference to that schedule.

Item No.	Brief Description of Goods	Quantity	Place of Delivery	Procuring Entity's Completion Schedule (---days as of signing of the contract)	Bidder's Offered Completion Schedule	
					Earliest Delivery	Latest Delivery
Lot 1	<p>Design, Supply, Installation and Commissioning of an 88.6 kWp Off-Grid Solar Photovoltaic Micro-Grid System as follows:</p> <p>PV module</p> <p>Mounting structure:</p> <p>Inverter</p> <p>Charge Controller</p> <p>Hybrid Inverter</p> <p>Batteries</p> <p>Web-based energy monitoring system</p> <p>Cabling and miscellaneous</p> <p>Grounding and protection system</p> <p>Fire Extinguisher</p> <p>Installation and commissioning materials for PV system (including all materials/components required for interconnection to on-site)</p> <p>Fencing, Lighting, Auxiliary services and Housing</p>	To be determined by bidder	Sebai Village, Region 1	210		

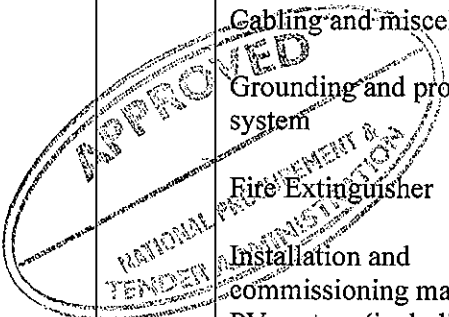

	infrastructure for batteries & Inverters					
Lot 2	Design, Supply & Construction of a 4 km Overhead Electrical Distribution Network at Sebai	To be determined by bidder	Sebai Village, Region 1	210		

Duly authorized to sign for and on behalf of

_____ (name of Bidder)

_____ (Full name)

_____ (Title)

_____ (Signature and seal)

TECHNICAL SPECIFICATIONS

1. General

The tender calling for convenient bids is dedicated to identify and contract a Supplier and Installer for the following services:

- 1.1 Designing, Supplying, installing and commissioning of an **88.6 kWp Off-Grid Solar Photovoltaic Micro-Grid System and Electrical Distribution Network in Sebai;**
- 1.2 Provide all technical documentations including user and operational manuals to the GEA. **The bidder must include all brochures, certifications, technical specifications, brand, and models of ALL equipment provided in one location in their submission in the following order.**
 - 1) PV modules
 - 2) PV Array Mounting Structure (Ground mounting)
 - 3) Grid Inverter/PV Inverters
 - 4) Charge Controller (if any)
 - 5) Hybrid Inverter
 - 6) Battery Energy Storage System
 - 7) Energy Monitoring System
 - 8) Schematic Diagram in accordance with NEC 2017 Article 690 and NEC 705
 - 9) Pad Mounted Transformer
 - 10) Pole Mounted Transformers
 - 11) MV & LV Conductors
 - 12) Rural Cut-out/LA lighting arrestors
 - 13) Complete Guy Sets
 - 14) Complete Earth Sets

Bidders must ensure that all equipment supplied under the contract is new, unused and of the most recent or current models, and that they incorporate all recent improvements in design and materials, unless provided otherwise in the Contract.

- 1.3 Provide 3 years after sales services to GEA. Bidders must provide a statement indicating its acceptance or otherwise of this requirement.

2. Climate and Site Conditions

Altitude	: <1000m above sea-level
Maximum daily mean temperature	: 35° C
Maximum outdoor ambient shade temperature	: 50° C
Minimum outdoor ambient shade temperature	: 15° C
Maximum relative humidity	: 100%
Wind Velocity	: 18 mph
Isokeraunic level	:70
Average Number of days with Rain p.a.	:120
Average Annual rainfall, cm	:150

Brass bornt antine

Sebai Village

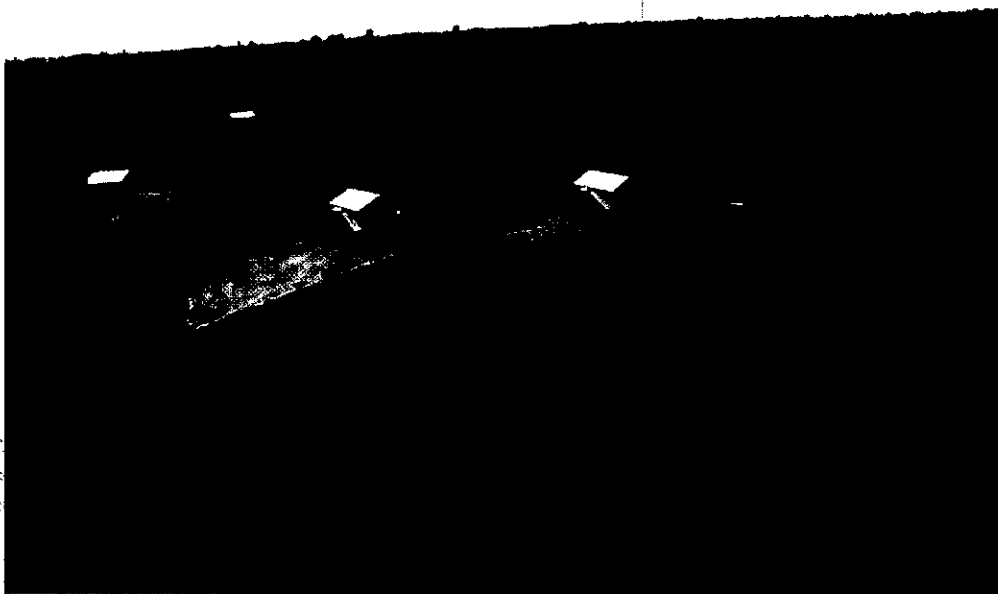

APPROVED
NATIONAL PROJECT
TENDER ADMINISTRATION

Bruce Bonnet Antine

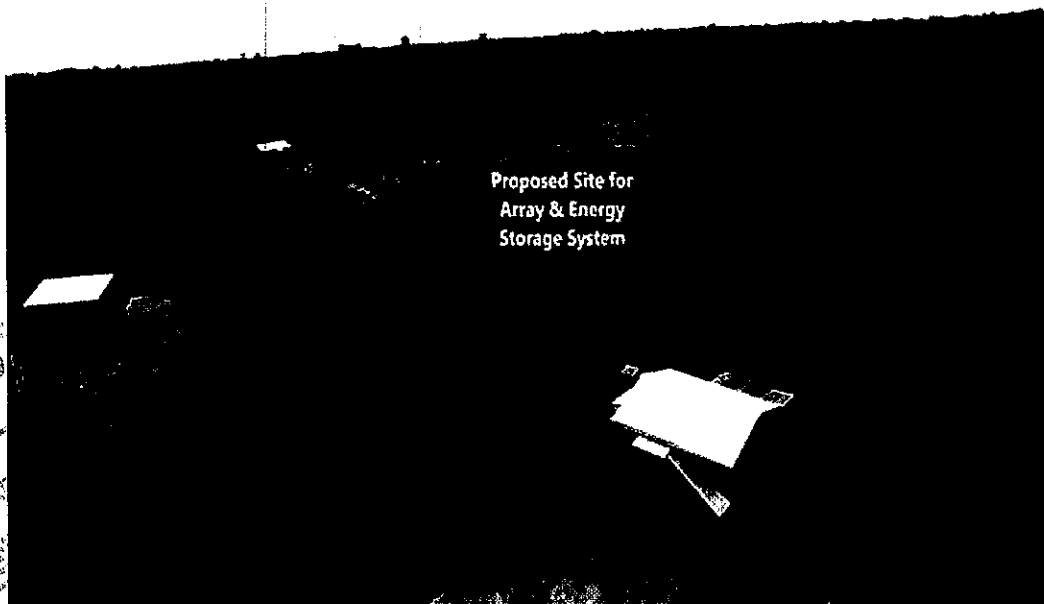

GPS coordinates of proposed site for solar array and PV components

Latitude: 7.838456°
Longitude: -59.913476°

3. Existing Power Supply Conditions & Network Configuration

Bidders are required to visit the site to determine appropriate equipment selection. The required electrical distribution network configuration is provided in the appendix.

Brian Fontaine

4. Specification of Required Hardware

4.1 General Remark

It is pointed out that the whole system should be designed in such a way that all components are resistant to climate conditions of the specific sites, specifically against corrosion. Special attention should be made in the equipment selection in such a way that the risk of theft and vandalism is minimised. Bolts and nuts of the PV arrays should be affixed in such a way that theft is minimised. The contractor is required to make all the necessary provisions, e.g. internet access where applicable, for ensuring that the PV system can be commissioned.

4.2 Photovoltaic Modules

- PV modules should be in accordance with international standards (IEC 61215, IEC 61730, IEC 61701, IEC 62804, UL1703 etc.) and the National Electrical Code 2017 Article 690;
- 300 watts or greater rated solar modules totaling 88.6kWp
- All modules should be made of crystalline silicon solar cells with conversion efficiency not less than 19.5% at Standard Test Condition
- All PV modules shall show the same capacity
- The Manufacturer should be internationally recognised and provide references and certificates on module testing.
- MC4 connectors for all Modules
- 20 years warranty on Modules

4.3 Ground Mounting Structure for PV Modules

- The mounting structure is ground mounted.
- The PV modules mounting structure must accommodate the PV modules supplied.
- The PV array mounting structure, including modules, and balance of system components shall be designed to withstand wind loads of at least 60 mph (3-second gust).
- Array mounting hardware supplied shall be compatible with the site considerations and the environment. Mounting structures of anodised aluminium material shall be provided. Mechanical hardware shall be durable and corrosion resistant. The use of ferrous metals (including but not limited to painted or plated steel), dissimilar metals in contact, or any wood or plastic components is not allowed.
- Special attention shall be paid to minimising the risk from exposed fasteners, sharp edges, and potential damage to the modules or support structure. All potentially hazardous hardware must be protected or shielded for safety.
- PV modules must be oriented in a southern direction with an inclination of between 8 to 10 degrees.
- The mounting structure must be able to absorb and transfer the mechanical loads to the ground via the foundation. Thus, the foundation should adhere to the following:

Foundation works

- Structural concrete @ 3000 psi or over at 28 days, using -3/4 stones with a height of not less than 16 inches.
- 1/2" diameter corrugated high tensile steel reinforcement or over (main bars) and 3/8" diameter steel bars as stirrups spaced at 8" crs to form a cage with a minimum of 2" concrete covers.
- Vertically smooth finish formwork for the sides of the foundation.

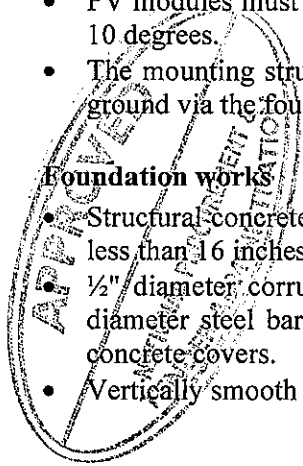

Brian Buntantine

- Compacted sand fill of 12" or more in two layers under foundation.
- 2" thick cement/sand (1:6) mix blinding upon compacted sand fill before pouring concrete
- Array mounting hardware supplied shall be compatible with the site considerations and the environment. Mounting structures of anodized aluminium material shall be provided. Mechanical hardware shall be durable and corrosion resistant. The use of ferrous metals (including but not limited to painted or plated steel), dissimilar metals in contact, or any wood or plastic components are not allowed.

Special attention shall be paid to minimizing the risk from exposed fasteners, sharp edges, and potential damage to the modules or support structure. All potentially hazardous hardware must be protected or shielded for safety.

4.4 Solar Photovoltaic Inverters

- The minimum size of each Inverter shall be 10 kW or above and totaling between 90% and 100% the solar array name plate capacity
- Master/Slave or String type
- **AC Grid Frequency – 60 Hz**
- **Operating Frequency range: Frequency Range ≥ 58.4 to ≤ 61.7 (Field Selectable)**
- Certificates and Compliance with International Standards Including (UL 1741-2010, UL 1699B, IEEE 1547-2003, IEEE 1547.1-2003, ANSI/IEEE C62.41, FCC Part 15 A & B)
- Pure Sinewave output;
- High efficiency (AC) $> 90\%$ @ P/Pn (AC) = 10%;
- Protection against overcurrent and overvoltage;
- Indications of status of operation (e.g. LED);
- Automatic disconnect from the grid in case of need
- Capability of connecting monitoring devices;
- Ground fault monitoring / grid monitoring.
- Safety measures (EN 61000, EN 60950 and others).
- Interface to the main grid (switchboard including manual disconnection device).
- 10 Years warranty

4.5 Hybrid Inverter

- Capacity totaling between 90 – 120% of PV inverters
- Master/ Slave or String Type;
- Maximum efficiency of 96% with 94.5% CEC efficiency;
- Intelligent battery management including state of charge calculation for maximum battery life;
- Integrated soft start/generator support;
- Versatile - complete for off-grid management as well as grid-tie battery backup/AC Coupling;
- Suitable for systems from up 100 kW and greater;
- Excellent overload characteristics with active temperature management;
- Certification UL 1741 / UL 1998;
- Modular, stackable design;
- Nominal Frequency 60 Hz;
- Frequency Range ≥ 58.4 to ≤ 61.7 (Field Selectable);
- Pure Sine Wave;
- Automatically transfers between inverter power and incoming AC power source;
- Compatible battery types Flooded, Gel, AGM, LiON;

Brian Bourmont

- Indications of status of operation (e.g. LED);
- Over voltage and under voltage protection;
- Over-temperature protection;
- Overload protection;
- Short circuit protection.
- 5 Year Standard Warranty;

4.6 Energy Storage System (Lithium Technology)

- Minimum Energy Storage capacity of 290kWh at C10
- Batteries should be deep cycle type and rechargeable;
- Lithium Ion/Iron technology;
- **Design for renewable energy applications specifically for hybrid/Off-Grid application;**
- Batteries are to be placed on racks to minimize the use of space;
- Bidders are to supply the racks which are to be fully fabricated from metal and resistant to rust. **Racks should be made to minimize the space required to store the batteries and allowance for effective ventilation. Welding, bolts and nuts used must be resistant to rust. Racks must be painted in two coats with anti-rust protective layer paint. The preferred color would be black. The battery racks MUST be adequately grounded.**
- **Bidders are to supply drawings of the racks with battery bank configuration;**
- **Minimum battery size is 300 Amp-Hour; C10**
- Sealed maintenance free;
- Manufacturer's data sheets containing battery performance specifications must be provided. Batteries must be procured from same make (manufacturer) having same ampere-Hour and voltage rating;
- 4,000 and above cycles at 80% depth of discharge
- Standards to be conformed to:
- UL 1989
- IEC 61427:1999
- UL 2054
- Manufacturing process must have conformed to environmental management standard ISO 14001.
- 6 Years Warranty on batteries;

The battery energy storage system should provide the primary function of allowing the maximum use of energy stored during the periods when solar energy is not available. It should be capable of providing rapid response when the intermittent source cannot meet the energy requirement of the village. A battery management/monitoring system must be included.

4.7 Energy Management System

The energy storage management system shall be capable of (but not limited) the following:

- State of Charge (SOC) management/tracking
- Control the PV curtailment
- Control Charging and discharge rates
- ESS monitoring (power, voltages, current, etc.)
- Active/Reactive power input/output
- Active/Reactive power import/export limiting
- Frequency response capable

Bruce Bontantone

- Provision to control a generator back-up
- Data logging
- 5 Years Warranty

4.8 Housing

All the elements of the solar PV system must be located in a suitable environment to maximize the lifespan of the equipment. The battery energy storage, battery inverter/s, energy management system and charge controller/s (if any) must be installed indoor in a powerhouse, PV inverters could be installed indoor in the powerhouse or outdoor under the PV panels. The powerhouse must be able to maintain the indoor temperature and conditions within the specifications of normal operation of the battery storage system.

4.9 Fencing

- The Contractor shall design, supply and install the perimeter fencing to surround and secure the complete solar PV power plant. Fencing of the premises is essential for protecting the asset against theft and to provide safety for the individuals involved in the operation and maintenance of the plant.
- The Contractor shall supply all necessary materials, equipment, tools and labour for the installation of a chain-link fence on the boundaries of the solar farm with rates inclusive of galvanizing poles, runners, RC pad foundation, end caps, non-corrosive paint, transportation, etc. to complete the installation

4.10 Lighting and auxiliary services

- The Contractor shall design, supply and install a lighting system of the whole fenced area. The provided lamps shall be 60W self-contained solar powered security lights with battery installed at 50 feet apart along the whole perimeter fence of the solar array.
- The Contractor shall design, supply and install a water supply network for cleaning of solar modules inclusive of the trestle, storage, water pump, adaptors, etc. to make the water supply system complete and functional.
- The Contractor shall install a Fire Detection System.

4.11 Schematic Diagram (PV System)

- A detailed system schematic design layout of all components and how they interconnect with each other **MUST** be provided in accordance with NEC 2017 Article 690. Drawings provided **MUST** be electrical schematic drawings and show all components and their respective rating (e.g., wires and circuit breaker sizes). All the hardware required for successful interconnection must be provided by the contractor.
- **The contractor is required to have a laminated copy of the system schematic installed at the location where the system components are sited.**

4.12 Cabling

Burns burnt out time

Cables exposed to the sun should show an adequate type designed to withstand harsh weather conditions (UV radiation, salty humidity etc.), e.g. type HN07-RNF and cables must be clearly identifiable (colour coded).

- Appropriate length USE-2 #10 AWG Sunlight Resistant Cable to connect solar panels in the designed configuration.

- The appropriate number of Solar Disconnect Switches and Combiner boxes.
- Appropriate size and number of interconnecting cables between combiner boxes and inverters. The distance from the combiner boxes to the inverters is **decided upon visits to the sites**.
- Appropriate size AC Interconnecting cables. The distance from the sites of the inverters to the main switchgear is to be **decided upon visits to the sites** by the Bidder.
- Appropriate size cables for electrical distribution network at the site.
- Power cables, communication cables & control cables of armoured and Solar grade

4.13 Monitoring System

The installation shall provide real-time monitoring through a computer software that features a local electric energy meter, power meter, data logger and appropriate current transformers to record electric consumption of the village from the grid and solar energy produced by the solar PV system and also provide a combined recording of all inverters/circuits loads. It should provide:

- Graphical and Numerical real-time energy information and long-term reports (total voltage, frequency, intensity, active power and energy demand of the micro-grid, measured in the output of the solar PV inverter/s and the low voltage side of the transformer; total power generated and energy produced by the solar system, measured in the output of the PV inverters; total power and energy produced by other sources of energy, if any);
- Historic Data; Data export via push or pull with an open data API.
- No service contracts
- 3 years warranty
- **Must** have at least one (1) ethernet styled registered jack (RJ) 45 data port.
- The monitoring system shall also feature a web-based application for remote monitoring.

4.14 Charge Controller (if applicable)

- Charge controller must be rated 25 % over system capacity size
- Nominal Battery voltage: 12/24/48 V
- Maximum Power Point Tracking (MPPT) charging technology
- Charge regulation method: Three stage (bulk, absorption, float) plus manual equalization
- Available monitoring and configuration
- Supported battery types: Flooded, GEL, AGM, Custom, Li
- Compatible with any brand of PV module, any grounding method
- Stand-alone application or integration with inverter charger system
- Certification: UL1741, CSA 107.1, EN 50178/IEC 62477-1
- 5 years warranty

4.15 Protections

The solar PV system should be provided with lightning & over voltage protection. The main aim in this protection shall be to reduce the overvoltage to a tolerable value before it reaches the PV or other subsystem components. The source of over voltage can be lightning, atmosphere disturbances etc. The entire space occupying the solar PV array shall be suitably protected against lightning by deploying the required number of lightning arrestors. Lightning protection should be provided as per IEC62305 standard. The protection against induced high-voltages shall be provided by the use of MOV type surge arrestors and suitable earthing such that induced transients find an alternate route to earth. In addition, the lightning arrestor/masts should also be earthed inside the array field.

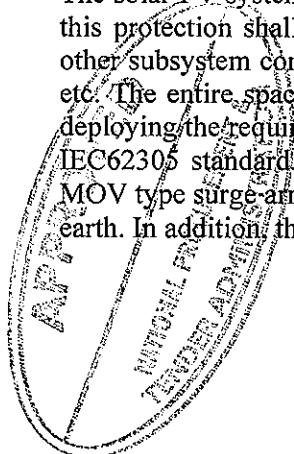

Brian Bantantine

4.14 Fire Extinguisher

- Can be of type: Carbon Dioxide, Dry Chemical, Clean Agent or Dry Powder
- 20 pounds (lbs.)
- Class C rated
- Operation type (P.A.S.S)

4.15 Pad Mounted Transformer

- Style: Pad Mount
- 150kVA, Three Phase Step-up transformer
- 480Vac – 13.8kVac, 60hz
 - Tolerance on the voltage ratio shall be $\geq \pm 0.5\%$;
- The Transformer shall be capable of supplying a continuous load equal to its kVA rating, under the following conditions:
 - the rated secondary voltage held constant by increasing the primary voltage to allow for regulation at all tap positions;
 - constant flux regulation;
 - continuous steady load;
 - design maximum ambient air temperature of 40°C;
 - 65°C average winding temperature rise and 80°C hot spot temperature rise
 - 65°C temperature rise of the insulating oil measured near the top of the tank.
- The transformer may be overloaded during emergency up to 150% of its continuous rating in accordance with IEC Publication 354. Bushings, tap changer and other current-carrying parts shall also be designed for this condition.
- Transformer Core and Windings: The core shall be constructed from high grade, non-ageing, cold rolled grain-oriented silicon steel laminations or superior material. The design shall avoid the presence of pockets that would prevent the complete emptying of the tank through the drain plug. The winding insulation shall be free from insulating compounds that are liable to soften, ooze out, shrink or collapse. It shall be non-catalytic and chemically inert in transformer oil during normal service. The windings and connections are to be braced to withstand shocks during transport, switching, short circuit or other transient conditions. The windings shall be uniformly insulated and the LV neutral points shall be insulated for full voltage. The windings conductor (both primary and secondary) shall be of **electrolytic copper** to give the optimum economic design.
- The windings of the transformer shall be connected Delta on the HV side and Wye (Star) on the LV side. The neutral of the LV winding shall be brought out to a separate terminal. The vector group shall be Dyn11.
- Taps shall be provided in the high voltage winding, two 2.5% taps above and below primary rating. Tap changing shall be carried out with the transformer off circuit and the tap changing handle shall be external to the transformer tank. The operating handle shall have provision for padlocking and shall give visual indication of the tap position without unlocking. Each tap-changer position and the tap voltage or percentage associated with it shall be clearly identifiable by reference to nameplate information. All positions of the tap changer shall be operative positions.
- Bushings & Terminations: Bushings shall be of the outdoor type and easily replaceable. All bushings shall have a minimum creepage distance of 20mm/kV for maximum phase to phase system voltage, and shall have a continuous rating of 200% of the transformer rating. The transformer shall be equipped with three high voltage bushing terminations for connection of the phases and four LV bushing terminations for the connection of the phases and a neutral. High Voltage and Low Voltage bushings shall be sized in accordance with ANSI standard.

- Earthing Terminals: Transformer shall be provided with two earthing terminals comprising an M12 ISO metric bolt and nut that shall be non-ferrous. It shall include a spring washer and a lock washer. External connecting strip between earthing terminal and neutral bushing(s) is not required.
- The transformer shall be capable of withstanding the thermal and dynamic effects of short circuits, as stated in the standards.
- The transformer shall be capable of withstanding for 2 seconds a bolted metallic short circuit on the terminals of either winding with rated voltage on the other winding and the tap-changer in any position.
- The transformer shall be equipped with lightning arrestors, with each arrestor electrically connected to each HV bushing and mechanically secured onto the tank. The lightning arrestors shall be capable of discharging lightning and switching surges and temporary power frequency over voltages. The Arrestors shall be capable of withstanding Maximum Continuous Operating Voltages (M.C.O.V) and rated for operation in 15 kV class distribution system. These arrestors shall be of Heavy Duty, Station Class / Distribution Class and Gapless Zinc Oxide type and shall be hermetically sealed units suitable for outdoor installation and mounting on distribution transformers. Additionally, the arrestors shall be suitable for heavily polluted atmospheric conditions with high incidences of lightning strikes.
- If short circuit tests have been carried out on the particular design of transformer offered, the test results shall be supplied with the bid.
- The flux density at any point of the magnetic circuit when the transformer is connected on the centre tap and operating at normal voltage and frequency shall be stated and shall not exceed 1.7 Tesla. The transformer must be capable of operating at 10% over voltage at 97% of rated frequency without saturation occurring or the flux density exceeding 1.9 tesla.
- The guaranteed impedance voltage measured at 75C and at rated voltage shall not exceed 5%.
- Dielectric fluid: Oil/Dimethyl Silicone/Mineral Oil
- Certification: IEEE Std C57.12.28, IEEE Std C57.12.3
- Outdoor rated: NEMA 3R or 4X
- Standard: IEC, ANSI
- The following insulation levels and dielectric tests shall apply:

Transformer insulation level

	HV Winding	LV Winding
Basic Impulse Insulation Level (kV)	95	-
Power Frequency voltage withstand level, Dry One-Minute (kV)	34	-
Power Frequency voltage withstand level, Wet 10-Second (kV)	30	10

- Manufacturer MUST be certified to a recognized Quality Management and Quality Assurance Standards such as ISO 9001 or ISO 9002, such certification shall be submitted as part of the bid documentation
- Except where modified by this specification, the transformer shall be designed, manufactured and tested in accordance with the latest editions of the following standards.

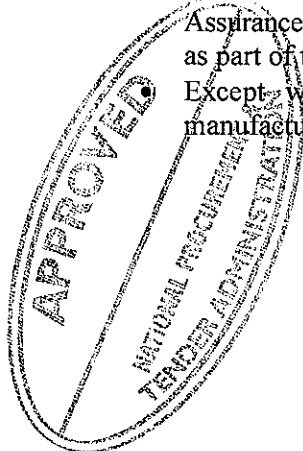

Brian Bontantime

ANSI/IEC	Subject
ANSI C57.12.20	Overhead-type distribution transformers
ANSI C57.12.90	Test Code for Distribution transformers
ANSI C76.1	Test Code for Outdoor Apparatus Bushings
IEC 71	Insulation Coordination.
IEC 76	Power Transformers.
IEC 137	Bushings for Alternating Voltages above 1000 V.
IEC 156	Method of determining Electric Strength of Insulating Oils.
IEC 354	Loading Guide for oil immersed Transformers
IEC 437	Radio Influence Voltage Measurement.
IEC 551	Determination of Transformer and Reactor Sound Levels.
IEC 616	Terminal and Tapping markings for power transformers.
IEC 722	Guide to the Lightning and Switching impulse testing of Power Transformers and Reactors.

In case of conflict, the order of precedence shall be:

- This Specification
- ANSI Standards
- IEC Standards
- Other Standards
- The transformer shall be provided with an anodized aluminium laser engraved nameplate, in accordance with IEEE C57.12, Table 9 - Nameplate C. The following attributes should be indicated on the aforementioned nameplate: type of transformer;
 - standard to which it is manufactured and tested;
 - manufacturer's name;
 - transformer serial number;
 - year of manufacture;
 - rated frequency in Hz;
 - rated voltages (primary and secondary);
 - number of phases;
 - rated power in kVA;
 - identification of internally mounted protective devices;
 - type of cooling (ONAN);
 - rated currents in A;
 - polarity;
 - chopped wave (short time) impulse voltage withstand level in kV;
 - power frequency withstand voltage in kV;
 - percentage impedance at 85°C;
 - load loss in kW at rated current;
 - no-load loss in kW at rated voltage and frequency;
 - continuous ambient temperature at which ratings apply in degree C (40);
 - top oil and winding temperature rise at rated load in degree C;
 - winding connection diagram;
 - total weight (core, windings and oil) in kg;
 - weight of core and windings in kg;
 - volume of oil in litres;
 - oil with less than 2ppm of PCB; and
 - name of the Procuring Entity (Cooperative Republic of Guyana.) *Brian Bonnet Antine*
- 2 years warranty
- The Bidder will submit complete technical data sheet, descriptive literature giving full technical details of the transformer offered, outline dimension drawing and general arrangement drawing showing component layout and general schematic diagrams, and

sample routine and type test reports for the type and rating of transformer.

4.16 Pole Mounted Transformers

- Style: Pole Mount
- 15kVA, Single Phase Step-down transformer
- The nominal primary voltage for the transformer shall be 13.8kV and the secondary voltages shall be 120/240V single phase three wire (13.8kVac – 120/240Vac, 60hz)
 - Tolerance on the voltage ratio shall be $\geq \pm 0.5\%$;

Taps shall be provided in the high voltage winding, two 2.5% taps above and below primary rating;

Tap changing and the tap changing mechanism shall have the following characteristics:

- tap changing shall be carried out with the transformer off circuit;
- tap changing handle shall be external to the transformer tank;
- tap positions shall be numbered as follows:

Tap 1	+ 5 %
Tap 2	+ 2.5%
Tap 3	0% (Principal Tap)
Tap 4	- 2.5 %
Tap 5	- 5.0 %

The operating handle shall have provision for padlocking and shall give visual indication of the tap position without unlocking.

Each tap-changer position and the tap voltage or percentage associated with it shall be clearly identifiable by reference to nameplate information. All positions of the tap changer shall be operative positions.

Tap change handles shall be fitted with gasketed covers, so that sealing of the transformer under normal conditions is independent of the switch shaft gland.

- The bidder shall state the percentage regulation at full load, power factor 1.0 and at full load power factor 0.85 lagging. The primary voltage variation is based on a winding temperature of 85degree C.
- Winding material: Aluminium/Copper
- Dielectric fluid: Oil/Dimethyl Silicone/Mineral Oil
- Certification: IEEE Std C57.12.20-2017
- Outdoor rated: NEMA 3R or 4X
- Tank Construction: The tank shall be of sealed construction. Transformers of the sealed type shall have tanks of rigid construction and be capable of withstanding the required internal pressures without deformation up to the maximum overload and short circuit conditions at maximum ambient temperature. The interior of the tank shall be sealed from the atmosphere, the gas plus oil volume remaining constant. The transformer shall remain effectively sealed for a top oil temperature range of minus 5°C to plus 105 °C. Transformer tanks shall be designed so that the completed transformer can be lifted and transported without permanent deformation or oil leakage. All sealing washers/gaskets shall be made of oil and heat resistant nitrile rubber or neoprene bonded cork seals suitable for temperature as stipulated in this specification. Surfaces at gasketed joints shall be such that an even face is presented to the gasket, thereby eliminating the necessity for the gasket to take up surface irregularities. The tank shall include an upper and lower support lug for direct pole mounting.
- Fittings: The following fittings shall be provided;
 - rating, diagram and terminal marking plate
 - tank grounding terminal
 - lifting lugs
 - manual pressure relief device

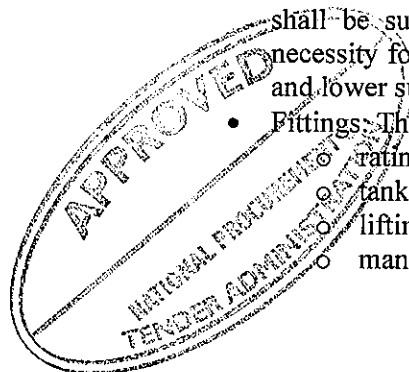

Brian Bontantime

- drain/sampling valve with plug
- Transformer Oil: The transformers shall be supplied filled with class 1 mineral oil conforming to IEC 296 or equivalent. The complete first filling shall be of new oil free from inhibitors and additives. The dielectric strength of the oil shall not be less than 60kV. If an anti-oxidant inhibitor is recommended, its use shall be subject to the Purchaser's approval.
- Each transformer shall be provided with a rating plate of weatherproof material showing the following items indelibly marked:
 - type of transformer;
 - standard to which it is manufactured and tested;
 - manufacturer's name;
 - transformer serial number;
 - year of manufacture;
 - rated frequency in Hz;
 - rated voltages (primary and secondary);
 - Number of phases;
 - rated power in kVA;
 - identification of internally mounted protective devices;
 - type of cooling (ONAN);
 - rated currents in A;
 - polarity;
 - chopped wave (short time) impulse voltage withstand level in kV;
 - power frequency withstand voltage in kV;
 - impedance voltage at rated current and frequency in percentage;
 - load loss in kW at rated current;
 - no-load loss in kW at rated voltage and frequency;
 - continuous ambient temperature at which ratings apply in degree C (40);
 - top oil and winding temperature rise at rated load in degree C;
 - winding connection diagram;
 - total weight in kg;
 - volume of oil in litres;
 - weight of core and windings in kg; and
 - name of the purchaser (Cooperative Republic of Guyana.)
- Standard: IEC, ANSI
- 18 Months Warranty
- The Bidder will submit complete technical data sheet, descriptive literature giving full technical details of the transformer offered, outline dimension drawing and general arrangement drawing showing component layout and general schematic diagrams, and sample routine and type test reports for the type and rating of transformer.

4.17 Rural Cutouts

- The distribution fuse cutouts shall be open, dropout expulsion type fuse cutouts suitable for installation in 60 Hz 13.8kV. The rated current shall be 100 A.

4.18 Lightning Arresters

- The arresters shall be fully compliant with ANSI/IEEE C62.11 Standard, and be fitted with mounting brackets. The arresters shall be similar to that shown in the diagram below. It shall be the metal oxide surge arrester type.

Brass bonnet antique

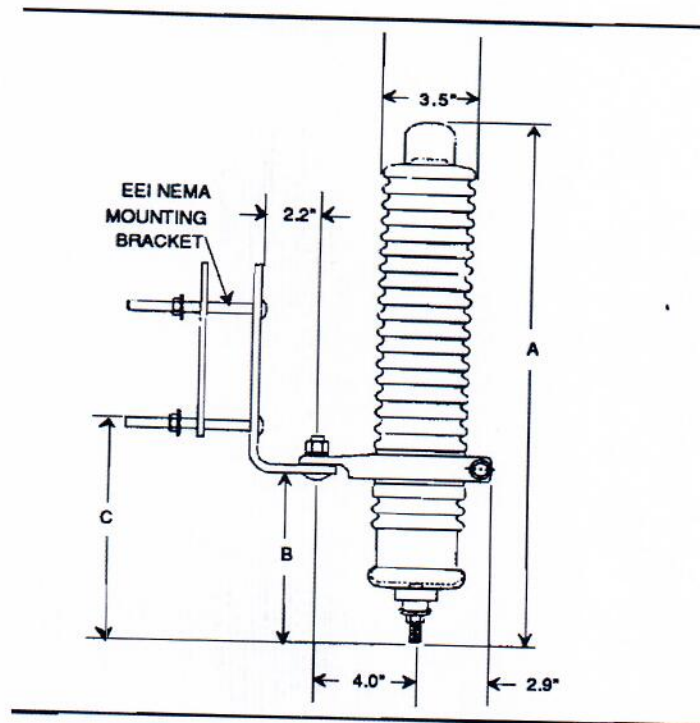

Arrester Rating	MCOV	Front-of-Wave Protection Level ¹	Maximum Discharge Voltage 8/20 μ s Current Wave						Switching Surge ²
			1.5 kA	3 kA	5 kA	10 kA	20 kA	40 kA	
kV rms	kV rms	kV crest							kV crest
18	15.3	64.2	49.1	52.1	55.1	60	67.6	81.4	44.1

5. Specification of Required Services

5.1 Systems Design

Bidders are required to visit the selected site and determine the best possible locations for the complete system, voltage and phase requirements for inverters and to become acquainted with the site for the installation of the systems. ***A detailed schematic diagram is required, showing system layout and include all interconnection equipment and points of connection for DC, AC, lightning and grounding protection.***

The successful bidder shall be required to provide all necessary infrastructure for mounting/positioning the inverters, controllers, energy storage system, switch gears and busbars. The successful bidder shall be required to construct/provide all necessary infrastructure to accommodate the inverters, controllers, energy storage system, switch gears and busbars. All infrastructure constructed must be structurally sound, secure and provide protection and adequate ventilation for the equipment installed.

The successful bidder is also responsible for designing the complete electrical distribution network and supplying and installation all materials inclusive of poles, line and line hardware, disconnects and other equipment necessary for the installation of a distribution network at this site to provide electricity **TO ALL** buildings. The bidder is also responsible for connecting the service from each building to the network. The end user voltage should be 120/240Vac.

Business as usual

¹ Based on a 10 kA current impulse that results in a discharge voltage cresting in 0.5 μ s.

² 45-60 μ s rise time 500 A surge.

System Operation

- a) The system must be configured in an AC or DC coupled configuration or a combination of the two. The solar PV system shall be the primary source of energy for buildings connected to the mini-grid.
- b) Electricity generated from the PV arrays shall be used for real-time consumption, and recharging of the battery energy storage system.
- c) The battery energy storage system should provide the primary function of allowing the maximum use of energy stored during the periods when solar energy is not available (at nights). It should be capable of providing rapid response when the intermittent source cannot meet the energy requirement of the consumers.
- d) The PV system should be capable of power generation scheduling for specified or predetermined periods of the day. Thus, the daily operation of the PV system shall be automated to turn ON and OFF power based on a predetermined schedule.

5.2 Installation (Solar Photovoltaic System)

- a) All installations are to be conducted in accordance with **NEC 2017 Article 690** which covers solar PV systems installation, protection (AC, DC and lightning) and grounding, Chapter 3 of the NEC 2017 which covers wiring method and materials, and **Article 705** for interconnection to the grid. **The Contractor is required to connect the PV system in a micro-grid configuration. All labels/ markings are to be provided by the contractor in accordance with the NEC 2017 Article 690 requirements.**
- b) The Government Electrical Inspectorate (GEI) requires that all solar installations must be provided with effective independent grounding/earthing systems. The contractor is therefore required to install a separate grounding system that when tested has ground resistance value of 25 ohms or less. The minimum size copper grounding rod to be use is 5/8inch x 8 feet for the solar PV installation.
- c) **The GEI also requires that the contractor applies and pay for an independent inspection certificate of all completed installations.** This inspection certificate is required by the GEA before a final completion certificate could be issued.
- d) The contractor is responsible for ensuring that the monitoring system is connected via wireless fidelity (Wi-Fi) or cable to an existing network at the location. All materials required for this task must be provided by the contractor. In the event of the absence of internet access at the location, alternative means **MUST** be provided by the contractor to ensure that online/remote monitoring over the world wide web occurs for the duration of the defects period.
- e) For all hybrid inverter installation, a main circuit breaker 1.25 times the size of the rated output (kW) of the Hybrid/Off-Grid inverters is required to be supplied and installed near the existing electrical distribution panels of the building.
- f) Damages to internal and external walls e.g. any holes, cuts or any actions/activities resulting in the defacing of the building during installation, must be repaired (neatly covered with appropriate moulding, paint or filling material) and returned to the original state at the expense of the contractor.

Brian Bontoutine

5.3 Installation (Electrical Distribution Network)

The bidder is required to Supply all materials, specialized equipment and construct a 2.5 km long, 13.8 kilovolts, three wire (3W), three phase, bare conductor, overhead medium voltage distribution network and an associated 4 km long, 120/240 volts, 60Hz, three wire (3W), single phase, bundled conductors, overhead low voltage distribution network. This overhead distribution network will be connected to the Solar PV Farm to power the residents of Sebai Village, North-West District, Region #1.

- (a) All works must be in accordance with the NESC and confirm to standard overhead line construction guidelines and practices.
- (b) Sag and Tension of all conductors must confirm to standard overhead line construction guidelines and practices.
- (c) All poles must be treated Wallaba type.
- (d) All crossarms must be treated Purpleheart type.
- (e) All medium voltage and low voltage insulated power cable utilized must be aluminium conductor.
- (f) All works will be subjected to inspections by an Authorized Personnel.
- (g) Approved Contractor must have previous experience in construction of Overhead Distribution Lines.
- (h) The contractor is expected to supply and install the associated concrete plinth, fence, and cables for both low voltage side from the Solar PV plant and medium voltage side to the 13.8 kV take-off structure.
- (i) Test and commission completed overhead distribution network after construction.
- (j) The contractor is responsible for all interconnections, including the connection of all the buildings to the PV system.

5.4 System Conditions

The following conditions MUST apply to the 13.8kV network.

Frequency	60 Hz	
Nominal system voltages:	13.8 kV	
	LV System (1ph)	120/240 V
Maximum system voltages:	13.8 kV System	15 kV
Nominal short circuit levels:	13.8 kV System	16 kA
Insulation Levels		
Basic Insulation Level (BIL)	13.8 kV System	95 kV
Power frequency one minute withstand	13.8kV System	34 kV
Neutral earthing arrangements:	13.8 kV System	N/A (Delta connected)
	LV System	solidly earthed

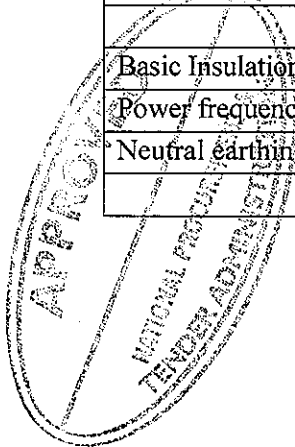

Brian Bontantse

5.5 Overhead Lines

Wherever other lines and/or equipment are sharing the same poles as the electricity lines, utmost care must be taken to avoid damage to property. The Contractor shall be responsible for any damage that may occur. It is advisable that the Contractor co-ordinates his activities with the relevant village representative prior to and during construction.

5.5.1 Drawings

Where available, drawings will be provided (Appendix). Such drawing and sheets are an integral part of this specification.

5.5.2 Pegging

The Contractor shall peg the pole positions to ensure that the line route is according to the design requirements.

A sighting procedure shall be followed to establish straight lines. Normally poles shall be aligned by "eye" using ranging rods. Where the range is too long for the naked eye, a theodolite shall be used. The pegging exercise shall be witnessed by the GEA's representative.

5.5.3 Pole Distribution

In distributing the poles, large, choice, close-grained poles shall be used for transformers, dead-end, angle, and corner poles.

5.5.4 Pole Setting

The minimum depth for setting poles shall be as follows:

Length of Poles (feet)	Setting in soil (feet)
30	5.5
40	6.0
45	6.5
50	7.0

"Setting in Soil" specifications shall apply as follows:

- a. Where poles are to be set in soil.
- b. Where there is a layer of soil of more than two (2) feet in depth over solid rock.
- c. Where the hole in solid rock is not substantially vertical or the diameter of the hole at the surface of the rock exceeds approximately twice the diameter of the pole at the same level.

On sloping ground, the depth of the hole shall always be measured from the low side of the hole. Poles shall be set so that alternate crossarm gains face in opposite direction, except at terminals and deadends where the gains of the last two poles shall be on the said side facing the terminal or deadend.

On unusually long spans, the poles shall be set so that the crossarms are fixed on the side of the pole away from the long span. Where pole op pins are used, they shall be on the opposite side of the pole from the gain, with the flat side against the pole.

Poles shall be set in alignment and plumb except at corners, terminals, angles, junction, or other point of strain, where they shall be set and raked against the strain so the conductors shall be in line.

Poles shall be raked against the conductor strain not less than one inch for each ten feet of pole

Brass Point Antine

length nor more than two inches for each ten feet of pole length after conductors are installed at the required tension.

Poles backfill shall be placed as soon as possible after pole erection in layers not exceeding six inches. Each layer shall be evenly placed and thoroughly compacted. Backfill in shall be built up to a minimum of 12" above the surface of the general ground level to allow for consolidation and settlement.

Should excavation be to a greater depth than specified, use sand compacted in 3" deep layers to bring the excavation to the required elevation.

Backfill material shall be sand or other suitable soil when excavated material is considered unsuitable. This material shall be free of leaves, wood and other deleterious matter.

Transformer poles shall also be fitted with one sleeper at ground level (5ft. sleeper). Sleepers shall be bolted to the pole.

In exceptionally wet ground conditions poles may require top and bottom sleepers.

5.5.5 Preparation of Poles and Assembly

Poles (supplied undrilled) shall be gained and drilled as indicated in the pole drawings. All bolt holes shall be 1/16" larger than the diameter of the bolts. (The correct lengths of bolts as required to match the various sizes of poles shall be used for all connections).

Pole butts shall be coated with an approved mix of tar, oil and creosote, unless otherwise specified, which shall be applied hot from the butt to a point 8 feet above the butt. The roof shall be painted with the same mixture.

Poles should be roofed, drilled and dressed at the pole dump sites. A power drill should be used to drill the holes efficiently.

Pole steps are to be located 18" apart. Pole steps in the vicinity of the lowest conductor shall be removed after work is completed.

Poles shall be framed as shown in the drawings with close attention being paid to lengths of crossarms in different locations. The crossarms shall be set horizontally with a maximum deviation of 2".

5.6 Grading of Line

When using high poles to clear obstacles such as buildings, foreign wire crossings, wide roads, etc., there shall be no upstrain on pin-type insulators in grading the line each way to lower poles.

5.7 Guys and Anchors

Guys shall be placed before the conductors are strung and shall be attached to the pole as shown in the Construction Drawings for the various types of structures.

All anchors and rods shall be in line with the strain and shall be so installed that approximately six inches of the rod remain out of the ground. In cultivated fields or other locations, as deemed necessary, the projection of the anchor rod above earth may be increased to a maximum of 12 inches to prevent burial of the rod eye. The backfill of all anchor holes must be thoroughly tamped the full depth, and the first 3 feet shall be placed in four well compacted layers of 8" each.

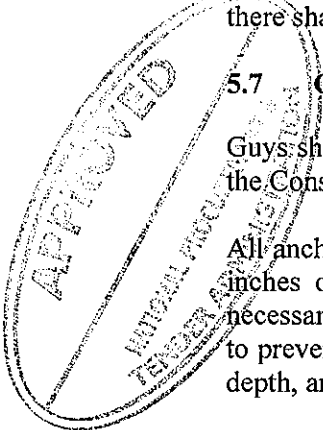

- Anchor blocks shall be 5ft. long.
- Preformed wraps shall be used to fix the guy wire.

5.8 Locknuts

A locknut shall be installed with each nut, eyenut or other fastener on all bolts or threaded hardware such as insulator pins, upset bolts, double arming bolts, etc., unless otherwise specified.

When installed in the structure, they shall extend at least 1/2" and not more than 2 1/2" beyond the nuts.

5.9 Insulators

Extreme care must be exercised in the distribution, storing and handling of insulators and special precautions taken to prevent chipping or cracking of the discs. Any damage to the insulators caused by the contractor negligence must be made good by him.

Ball sockets of suspension insulators must be clean inside and free from dust, small stones, etc. before the ball is inserted. The ball shall be prevented from leaving the socket by the insertion of a cotter pin and the ends of all cotter pins shall be spread 1" apart after insertion to prevent their falling out under working conditions.

Pin insulators shall be tight on pins and on target construction, the top groove must be in line with the conductor after tying in. The conductors shall be tied in the top groove of the insulator on tangent poles and on the side of the insulator away from the strain at angles.

Polymeric insulators will be used for conductor dead-end.

5.10 Conductors

Conductors must be handled with care. Conductors shall not be trampled on nor run over by vehicles. Each reel shall be examined and the wire shall be inspected for cuts, kinks, or other damage. Damaged portions shall be cut out and the conductor spliced. The conductors shall be pulled over suitable rollers or stringing blocks properly mounted on pole or crossarm if necessary, to prevent binding while stringing.

Loading of conductor drums may be performed by a small mobile crane or fork lift. Drums may only be rolled over short distances and must always be rolled in the direction of rotation corresponding with the arrow on the drum.

Drums are not to be dropped from lorries. Any conductor damaged by such mishandling may be rejected by the Engineer and the landed cost of replacement charged to the Contractor.

The lagging on the drums is to be retained until the drums are finally mounted on spindles prior to pull out.

In pulling out conductor the drum shall be supported on suitable jacks levelled and secured with the drum free to revolve. An efficient brake shall be provided to prevent the conductor jumping the drum when pulling ceases. Where convenient, the conductor may be pulled by a towing vehicle to give slack. The conductor shall be lifted by approved means, e.g., a lifting shoe and placed through the above-mentioned stringing blocks.

During pull out, the conductor is to be prevented from rubbing on hard abrasive surfaces. Temporary scaffolding may be required to scale steel fences and other abrasive objects along the route. Special structures such as temporary poles will be needed to gain clearance at road crossing and navigable

waterways as well as existing high voltage wires. Proposals for these crossings must be worked out well in advance and must be approved by the Engineer. During work on such crossings the Engineer will be in attendance and his instructions relating to safety must be adhered to.

In cases where circuits to be crossed can be switched out, the permit to work system will be in force. The Contractor shall be required to obtain written clearance from the Engineer before assuming the circuits are dead.

Wherever possible the conductor must be kept clear of water.

If conductors are damaged beyond repair because of the Contractor's equipment, methods or lack of adequate protection, the damaged section shall be removed and replaced at the expense of the Contractor.

With pin-type insulators the conductors shall be tied in the top groove of the insulator on tangent poles and on the side of the insulator away from the strain at angles. Pin-type insulators shall be tight on the pins and on tangent construction the top groove must be in line with the conductor after tying in.

For neutral and secondary conductors on poles, insulated brackets may be substituted for the single and double upset bolts on angles of 0 to 5 degrees in locations known to be subject to considerable conductor vibration.

All conductors shall be cleaned thoroughly by wire brushing before splicing or the installation of a connector or clamp. A suitable inhibitor shall be used before splicing or applying connectors over aluminium conductor.

5.11 Splices and Dead ends

In exceptional circumstances conductors may be spliced using a crimped connector. Deadens shall be fitted with preformed wraps. There shall be not more than one splice per conductor in any span and splicing sleeves shall be located at least ten feet from the conductor support. No splices shall be used in spans adjacent to section poles, nor in spans of road, railway lines nor in spans of any important crossing.

5.12 Taps and Jumpers

Jumpers and other leads connected to line conductors shall have sufficient slack to allow free movement of the conductors. Where slack is not shown on the Construction Drawings, it will be provided by at least two bends in vertical plane, or one in a horizontal plane, or the equivalent.

5.13 Connectors

All connections shall be made using crimped connectors, type Burndy or equivalent.

5.14 Line Clearance to ground

The minimum line clearances to ground for voltages from 750V to 15kV shall be in accordance with the table below.

Situation	Min. Clearances Metres (Feet)
Over Open Country	4.60 (15)
Over a Road	7.5 (25)
Along A Road	7 (23)
Over Telecommunications Lines	2 (6)
Over Rivers	7.5 (25)

Over Railways	8.6 (28)
Over LV Lines	2 (6)
Near Buildings: Vertical* (roof or projection not accessible to pedestrians)	3 (10)
Near Buildings: Vertical* (roof or balconies accessible to pedestrians)	4.6 (15)
Horizontal	2.4 (8)

5.15 Stringing and Sagging

Conductors shall be sagged in accordance with tables below, and conductor manufacturer recommendations.

Conductor Sagging - Maximum tension and sag

Ruling span Feet	Cosmos (477)		Tulip (336.)		4/0 Oxlip		1/0 Poppy	
	Sag inches	Tension lbs.	Sag inches	Tension lbs.	Sag inches	Tension lbs.	Sag inches	Tension lbs.
250	30	2423	31.2	1773	33.6	1223	39	704
225	26.5	2131	27.5	1629	29.7	1120	38	658
200	23.3	1915	24.2	1463	26.2	1004	29.8	590
175	20.3	1691	21	1291	22.5	895	25.4	530
150	17.1	1467	17.8	1119	18.9	783	21.1	469
125	14	1245	14.3	967	15.3	671	16.8	409
100	11	1014	11	805	11.8	557	12.8	343
75	7.38	850	7.6	655	8.1	457	8.8	281
50	4.38	588	4.8	461	5.1	322	5.7	193

Conductor Sagging - Initial tension and sag

Ruling span Feet	Cosmos (477)		Tulip (336.)		4/0 Oxlip		1/0 Poppy	
	Sag inches	Tension lbs.	Sag inches	Tension lbs.	Sag inches	Tension lbs.	Sag inches	Tension lbs.
250	25	1673	25	1178	25	738	25	368
225	22.5	1505	22.5	1060	22.5	664	22.5	331
200	20	1338	20	942	20	590	20	295
175	17.5	1171	17.5	824	17.5	517	17.5	258
150	15	1004	15	707	15	443	15	221
125	12.5	836	12.5	588.9	12.5	369	12.5	184
100	10	669	10	471	10	295	10	147
75	7.5	502	7.5	353	7.5	221	7.5	110
50	5	335	5	236	5	148	5	74

All conductors shall be sagged evenly, except that a maximum increase of three inches of the specified sag in any span will be acceptable. However, under no circumstances will a decrease in the specified sag be allowed.

Brass Bonit Antine

The work includes stringing and sagging of conductors and the installation of all joints, assemblies and terminals. The entire operation will be observed by the Engineer or his representative and every facility shall be given the observer or engineer to thoroughly inspect every detail of the work. The equipment used for the operation shall be such that the conductors are not pinched, twisted or damaged in any way.

For pulling out and subsequent sagging, the conductors shall be supported in approved stringing blocks, having close fitting but free running aluminium sheaves on roller bearings. These blocks shall be so attached to the structure that they are at the same height as the conductor groove on the insulator.

During stringing/sagging operations, the contractor must ensure that undue stresses are not imposed on the structures or insulators. At no time during pull out and prior to sagging should the tension in the conductor be greater than 50% of its ultimate tensile strength nor should the sag be less than 80% of respective sag for any specific span.

The Contractor shall not use tangent poles as temporary dead ends unless suitably back-guyed. At no time shall the conductor be held in tension by pin insulators.

The Contractor shall have in operation a suitably clear and reliable means of communication between check spans, sighting spans, conductor anchor points and conductors tensioning point throughout the sagging and tensioning exercise. It shall preferably be portable radios, but if not available, flags may be used.

The following are the typical tools/equipment required: -

- Chain jack
- Conductor grips
- Conductor travellers
- Drum jacks
- Tractor with winch

However, the tools/equipment should not be limited to any or all of the above. For long lines use tractor for pulling, preferably all three (3) conductors simultaneously. Use light rope as pilot especially when pulling over the lines on difficult terrain. Ensure conductor on rollers at each support to minimise abrasion and friction, also to prevent loops and kinks. Alternatively, tractor may be used with capstan attached to wheel. This method ensures adequate coiling up of rope.

Pull up and tensioning shall follow the sequence below.

- a) first pull up by vehicle
- b) next - further tensioning by winch
- c) final tensioning by chain jack at pole top
- d) tension - two outer conductors simultaneously
- e) adjust temporarily to allow structures to lean forward by approximately 2" to compensate for tensioning in succeeding (adjacent) section
- f) final adjustment to sag
 - a. select longest flat span in section (also) two other spans at opposite extremities if the section is longer than 500 metres;
 - b. use light boards to pull up conductors to correct sag;
 - c. after correct sag, mark conductor for permanent clamp position, apply Armour Tape and tie off.

The following line checks shall be carried out.

- a) final pole depths use 10' mark as gauge
- b) balance loading on stays
- c) damaged insulators
- d) clearances
 - a. ground
 - b. buildings

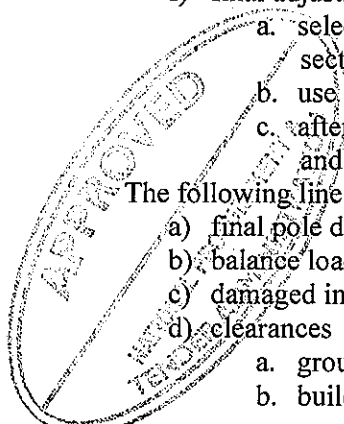

Brian Bontantini

c. other circuits

5.15.1 Sagging – use of sag charts

The sag of the conductors shall be determined in the field from the span length, the section ruling span, the temperature and the sag charts supplied by the Engineer. Sag measurements shall be made on one principal sighting span and up to two check spans for any sag section. These spans and the respective sags will normally be agreed upon beforehand with the Project Manager.

An accuracy of +/-4% with respect to the sag chart is required for the conductors. A maximum tolerance in sag of 4" will be allowed between any two conductors in the same span.

5.16 Secondaries and Service Drops

Secondary conductors may be bare or covered wires but the normal standard is to use multi-conductor service cable with bare neutral. The conductors shall be sagged in accordance with the manufacturers' recommendations.

Secondaries and service drops shall be so installed as not to obstruct climbing space. There shall not be more than one splice per conductor in any span, and spicing sleeves shall be located at least ten feet from the conductor support. Where the same covered conductors or service cables are to be used for the secondary and service drop, they may be installed in one continuous run.

5.17 Earthing/Grounding

Details of earthing requirements are shown on the construction drawings.

The following parts of the system are to be grounded:

- Common neutral wire.
- Neutral at consumer's services entrance.
- Transformer windings as specified.
- Tank or frame of transformers, metering equipment, capacitors, regulators and other line equipment.
- Steel platforms and beams in substation or on poles.
- Fencing including gates used to enclose transformer or capacitor installations.
- Cable sheaths.
- GOAB switch handles.

Ground rods shall be driven full length in undisturbed earth. The top shall be at least 12 inches below the surface of the earth. The ground wire shall be attached to the rod with a clamp and secured to the pole with staples. The staples on the ground wire shall be spaced two feet apart except for a distance of eight feet above the ground and eight feet down from the top of the pole where they shall be six inches apart.

All equipment shall have at least two connections from the frame, case or tank to the multi-grounded neutral conductor.

The equipment ground, neutral wires, and lightning-protective equipment shall be interconnected and attached to a common ground wire.

Temporary earths for the purpose of construction work shall be installed in accordance with standard practice, on both sides of the work area and at a reasonable distance away, so as to provide safe protection against lightning strikes or accidental energising of line or any other electrical hazard, to any personnel during construction.

Brian Bontantone

5.18 Clearing of Right-of-Way (RoW)

In preparing the right-of-way, trees shall be removed, underbrush cleared and trees trimmed so that the RoW shall be clear from the ground up and of the width required. Trees fronting each side of the RoW shall be trimmed symmetrically unless otherwise specified. Dead trees beyond the RoW which would strike the line in falling and which would require topping if not removed, shall either be removed or topped except that shade, fruit, or ornamental trees shall be trimmed and not removed unless otherwise authorised.

Spraying shall be performed in such manner, at such pressure and under such wind conditions that drift of spray material to adjacent vegetation will be avoided. Spraying should be performed the same day that brush and tree cutting removal work is completed but in no event later than 72 hours from the time tree cutting is performed. If moisture or wind conditions prevent treatment in accordance with the above, spraying shall be performed as soon thereafter as possible.

5.19 Installation of Equipment

5.19.1 Transformers

Transformers shall be installed in accordance with the detailed construction drawings.

5.19.2 Insulators

Insulators shall be installed in accordance with the detailed construction drawings.

5.20 Safety

The work shall be carried out with every reasonable precaution and provisions being taken for the safety of those concerned in the preparation, excavation, erection, stringing and all other operations as well as for persons in the vicinity.

Wherever and whenever power outages are required, the Contractor must notify the GEA's representative, in writing, at least 48 hours in advance of such outages. Prior to commencement of work in areas where power outages are necessary, the Contractor shall firstly satisfy himself with the isolations granted and obtain permission to work on de-energised lines from the System Control Department of the GEA.

The responsibilities shall at all times rest with the Contractor. The Contractor shall ensure that the conductors of the line are suitably earthed as construction work proceeds.

5.21 Inspection and Testing

Inspection and testing shall conform to the Quality Assurance requirements of this Specification.

The Contractor shall inspect the Works prior to testing to ensure compliance with the specified requirements and the drawings.

The inspection of the Works shall be attended and witnessed by the Project Manager or his representative.

5.22 Drawing and Records

The GEA will issue the drawings, both layouts and detail guides, required by the Contractor for the construction of the Works.

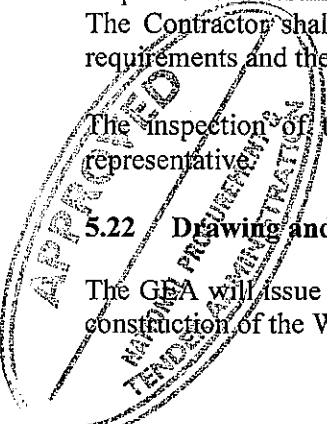

Brian Bourntantine

The Contractor will however prepare working sketches as required, to describe particular details to his construction team. Such details must not conflict with the GEA furnished drawings and in case of doubt, the working sketches must be submitted to the Project Manager for approval. For the "as constructed" records, three (3) copies each (legibly amended in red) of the following shall be re-submitted to the Engineer.

- i. structure lists
- ii. plan profiles
- iii. three complete sets of maps (1":100')

These shall be marked up as accurately as possible showing the centre line of the route and the actual pole position relative to (on) that centre line. Access routes are also to be included.

5.23 Compliance with Regulations

All the equipment and accessories shall comply in every respect with the Regulations and Acts in force in Guyana.

The equipment and connections shall be designed and arranged to minimise the risk of fire and any damage that might be caused in the event of fire.

To ensure that the Works are in accordance with the Specification, with the regulations and with relevant authorised international standards, the Contractor shall have in place suitable Quality Assurance Programmes and Procedures to ensure that all activities are being controlled as necessary.

The quality assurance arrangements shall conform preferably to the relevant requirements of ISO 9001 or ISO 9002 as appropriate.

5.24 Progress Reporting

The Contractor shall submit progress reports on a monthly basis by the end of the first week of the month for the previous month's progress.

5.25 Delivery of Equipment to Installation Sites

The Bidder is fully responsible for organising and guaranteeing timely delivery and transport of the equipment to the installation site.

The Bidder is requested to present detailed information on the schedule of delivery and transport modalities of the equipment to the project site. Close coordination with responsible staff from the procuring entity is recommended. The Bidder is requested to consider site conditions having a potential influence on delivery and installation.

5.26 Transfer of Ownership

An Acceptance Inspection will be organised by the procuring entity and in presence of the Seller will allow for the issuance of a certificate to transfer ownership to the Purchaser.

5.27 Warranty

Two types of warranty have to be offered by the Bidder:

- a) Warranty on hardware failures on all products offered and used according to international established terms;

Brian Bonnet Antine

- b) Warranty on the proper operation of the provided equipment according to the specification and terms fixed in the contract between the Seller and the procuring entity.

5.28 After Sales Service

The Supplier must provide a local after-sales service of no less than 3 years.

5.29 Commissioning

Commissioning refers to inspection and testing the solar PV system after installation and certifying that it operates as expected and is installed according to the design plans and complies with NEC 2017 Articles 690 and 705. It also includes the inspection and testing of the electrical distribution network.

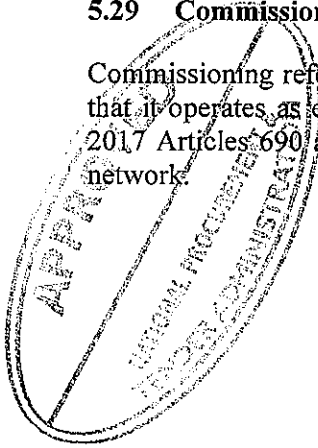

Brian Bontantse

SUPPLIER'S BID (Lot 1)

TO: _____
(Name and address of Procuring Entity)

Dear Sir / Madam,

Having examined the bidding documents including Annexes and Addenda No _____ [specify numbers], the receipt of which is hereby acknowledged, we offer to execute the **Design, Supply, Installation and Commissioning of an 88.6 kWp Off-Grid Solar Photovoltaic Micro-Grid in Sebai** in accordance with the Contract conditions attached herein for the total amount of _____,

The Value Added Tax (VAT) for our bid is _____
(amount in words and figures)

The Price of our bid, including VAT is _____
(insert the total bid price in words and figures, in Guyana dollars as per details given in the price schedule attached)

Alternative bids (at the Employer's request):
Also, we offer to execute the works pursuant to alternative bids for the amount of _____ GYD

- (a) We, including all subcontractors, regarding any part of the Contract, in accordance with the bidding documents, have no conflict of interests pursuant to subclause 2 (i) of the Instructions to Bidders;
- (b) We, including all subcontractors, regarding any part of the Contract, in accordance with the bidding documents, have not been declared by the authorized State body on procurement to be ineligible, or are not ineligible, in accordance with the legislation of Guyana.

We undertake, if our Bid is accepted, to supply the Goods, in accordance with a delivery schedule given in the Schedule of Requirements.

If our Bid is accepted, we undertake to furnish the Performance security in the form of _____ to the amount of _____, comprising _____% of the Contract Price in order to execute the Contract properly and within the time period(s) specified in the Bidding Documents.

We hereby confirm that this bid shall be valid during _____ days starting from the date established for bid opening, and it shall be binding until the expiry of the indicated period.

We understand that you are not bound to accept the lowest or any bid you receive.

Dated the _____ day of _____ 202__.

Duly authorized to sign the Bid for and on behalf of

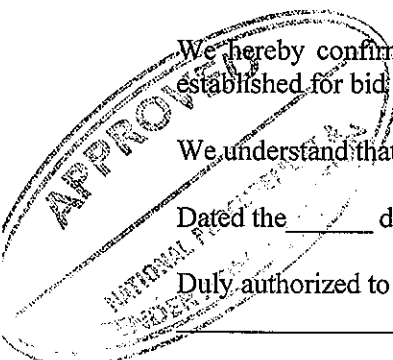

_____ (name of Supplier)
 _____ (Full name) _____ (Title) _____ (Signature and seal)

SUPPLIER'S BID (Lot 2)

TO: _____
(Name and address of Procuring Entity)

Dear Sir / Madam,

Having examined the bidding documents including Annexes and Addenda No _____ [specify numbers], the receipt of which is hereby acknowledged, we offer to execute the **Design, Supply & Construction of a 4 km Overhead Electrical Distribution Network in Sebai** in accordance with the Contract conditions attached herein for the total amount of _____,

The Value Added Tax (VAT) for our bid is

.....
(amount in words and figures)

The Price of our bid, including VAT is

.....
(insert the total bid price in words and figures, in Guyana dollars as per details given in the price schedule attached)

Alternative bids (at the Employer's request):

Also, we offer to execute the works pursuant to alternative bids for the amount of _____ GYD

- (a) We, including all subcontractors, regarding any part of the Contract, in accordance with the bidding documents, have no conflict of interests pursuant to subclause 2 (i) of the Instructions to Bidders;
- (b) We, including all subcontractors, regarding any part of the Contract, in accordance with the bidding documents, have not been declared by the authorized State body on procurement to be ineligible, or are not ineligible, in accordance with the legislation of Guyana.

We undertake, if our Bid is accepted, to supply the Goods, in accordance with a delivery schedule given in the Schedule of Requirements.

If our Bid is accepted, we undertake to furnish the Performance security in the form of _____ to the amount of _____, comprising _____ % of the Contract Price in order to execute the Contract properly and within the time period(s) specified in the Bidding Documents.

We hereby confirm that this bid shall be valid during _____ days starting from the date established for bid opening, and it shall be binding until the expiry of the indicated period.

We understand that you are not bound to accept the lowest or any bid you receive.

Dated the _____ day of _____ 202__.

Duly authorized to sign the Bid for and on behalf of

(name of Supplier)

(Full name)

(Title)

(Signature and seal)

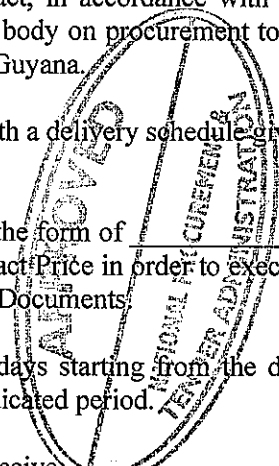

PRICE SCHEDULE

Item No.	Brief Description of Goods	Quantity	Unit Price (GYD)	Delivery Cost plus taxes	Installation Cost plus taxes	Total Cost (GYD)
<p>Lot 1</p>	<p>Design, Supply, Installation and Commissioning of an 88.6 kWp Off-Grid Solar Photovoltaic Micro-Grid System as follows:</p> <ul style="list-style-type: none"> - PV module - Mounting structure: - Inverter - Charge Controller - Hybrid Inverter - Energy Storage System - Web-based energy monitoring system - Cabling and miscellaneous - Grounding and protection system - Fire Extinguisher - Installation and commissioning materials for PV system (including all materials/components required for interconnection to on-site) - Fencing, Lighting, Auxiliary services 					

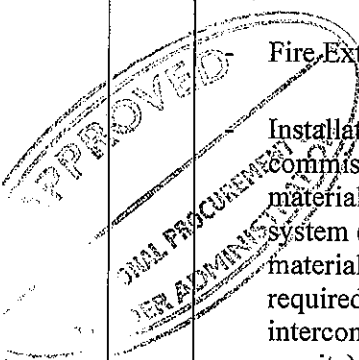

	and Housing infrastructure for batteries & Inverters				
Lot 2	Design, Supply & Construction of a 4 km Overhead Electrical Distribution Network at Sebai as follows:				
	- 150 kVA, 480V-13.8kV, 60Hz Step-up Pad Mounted 3PH Transformer	One (1)			
	- 15 kVA, 13.8kV - 120/240V, 60Hz Step-down Pole Mounted 1PH Transformer	Seven (7)			
	Poles				
	- Twelve meters (12m) Wallaba Poles	Forty-five (45)			
	- Nine meters (9m) Wallaba Poles	Seventy-five (75)			
	- Pole Step, Drive Hook 5/8" x 10"	One thousand and twenty (1,020)			
	- Pole Treatment, Tar/Creosate	One hundred and seventy-two (172)			
	- Sleeper "U" Bolt	One hundred and eighty-four (184)			
	- Sleeper Large	One hundred and seven (107)			
- Sleeper Small	One hundred and seven (107)				
Insulators					
- Insulator, Dead End Suspension (Polymer)	One hundred and thirty-two (132)				

- Insulator, Pin Type, ANSI Class, 55-5	Eighty-seven (87)			
- Insulator, Spool, ANSI Class, 53-2	Two hundred and fifty (250)			
- Single spool clevis	Two hundred and fifty (250)			
- Ductile dead-end thimble (DDT-07)	One hundred and thirty-two (132)			
Terminations				
- Binding Wire - 1/8" Dia. Aluminium	One hundred and seventy-two meters (172m)			
- Preformed wrap for (deadend) Oxlip/Lepas Conductor - 100mm ²	Two hundred and fifty (250)			
- Preformed wrap for Poppy - AWG 1/0 (50mm ²), Al.	One hundred and thirty-two (132)			
Crossarms				
- Crossarm 1.37m (4ft 6") x 4 1/2" x 3 1/2" (deep)	Seven (7)			
- Crossarm 2.44m (8ft x 4 1/2") x 3 1/2" (deep)	Ninety-six (96)			
- Crossarm brace, flat 20"	Fourteen (14)			
- Crossarm brace, flat 32"	One hundred and thirty-six (136)			
- Crossarm pin 1" Thread 1 1/2"	Sixty-three (63)			

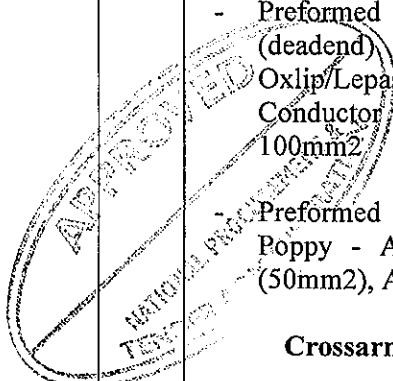

<ul style="list-style-type: none"> - Pole Top 1" Thread 20" 	<p>Twenty-four (24)</p>				
Guys					
<ul style="list-style-type: none"> - Anchor Rod, Thimbleye 7ft x 5/8" 	<p>Thirty-five (35)</p>				
<ul style="list-style-type: none"> - Washer 5/8" Curved for Guy Rod 	<p>Thirty-five (35)</p>				
<ul style="list-style-type: none"> - Eye Angle Thimble eye for attaching Guy to Pole 	<p>Thirty-five (35)</p>				
<ul style="list-style-type: none"> - Guy Block - Large Sleeper 	<p>Thirty-five (35)</p>				
<ul style="list-style-type: none"> - Guy preformed wrap, for 7/16" GS Guy Wire 	<p>One hundred and forty (140)</p>				
<ul style="list-style-type: none"> - Guy Strain Insulator, 15kV, 7/16" cable, ANSI 54-2 	<p>Thirty-five (35)</p>				
<ul style="list-style-type: none"> - Guy wire, 7Strand Galvanised. 7/16" dia. Utilities type 	<p>Five hundred and forty-three (543)</p>				
Conductors					
<ul style="list-style-type: none"> - Bare aluminium conductor Poppy AAC), Size 1/0 AWG for MY network 	<p>Seven thousand six hundred and forty-eight meters (7,648m)</p>				
<ul style="list-style-type: none"> - Secondary Conductor, Triplex 19 Strand A-WG 4/0 (100mm²), Aluminium Lepas (mts.) 	<p>Ninety-one meters (91m)</p>				
<ul style="list-style-type: none"> - Bundled insulated aluminium phase conductor with bare aluminium neutral (triplex service wire) - to serve as 	<p>One thousand two hundred and seventy-five meters (1,275m)</p>				

	<p>consumer service mains</p> <ul style="list-style-type: none"> - Bundled insulated aluminium phase conductor with bare aluminium neutral (triplex 19 strand conductor – equivalent size 4/0 AWG for LV network) <p>Connectors</p> <ul style="list-style-type: none"> - Primary conductor tap connector (50mm² to 50mm² - Poppy to Poppy) Line to RCO - Secondary Connector AWG 100mm² to 100mm² (Lepas/Oxlip to Lepas/Oxlip) <p>RCO's, Lightning Arrestors & Switches</p> <ul style="list-style-type: none"> - Rural Cutout/LA Arrestor, Combination Type (100 Amp, 15kV Class – including Earth at the take-off structure to allow for protection and isolation of the Solar PV Plant. - Single Pole Disconnects (SPD) at designated locations for isolation in case of maintenance and emergencies <p>Fuses & Cut Outs</p> <ul style="list-style-type: none"> - Primary Fuse Links 60amp Type K or T Earthing 	<p>Four thousand and sixty meters (4,060m)</p> <p>Eighty-nine (89)</p> <p>One hundred and eleven (111)</p> <p>Seventeen (17)</p> <p>Six (6)</p> <p>Three (3)</p>				
--	---	--	--	--	--	--

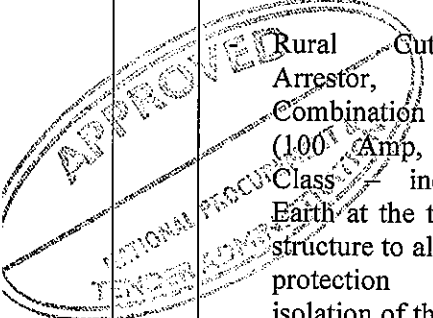

- Ground Copper Conductor (mts.) - 20mm2	One thousand one hundred (1,100)			
- Ground rod	Fifty-five (55)			
- Ground wire connector 100mm2 (AWG4/0) to 20mm2 (AWG4)	Fifty-five (55)			
- Ground wire connector 20mm2 to 20mm2	Fifty-five (55)			
- Staple 1" x 5/8" x 0.12	Fifty-five (55)			
- PVC Flexible Pipe 1/2" O/D	Two hundred and twenty meters (220m)			
- Pipe staples 2" x 5/8" x 0.162	Two hundred and seventy-five meters (275m)			
- Carriage Bolt 3/8", 4 1/2" long	One hundred and fifty (150)			
- Eye nut, Standard 5/8"	Twenty-four (24)			
- Lag Screw 3/8", 3"	Seventy-five (75)			
- Machine Bolt 3/4" 14" long	Fourteen (14)			
- Machine Bolt 5/8" 12" long	Two hundred and thirty-eight (238)			
- Machine Bolt 5/8" 16" long	Thirty (30)			
- Machine Bolt 5/8" 18" long	One (1)			

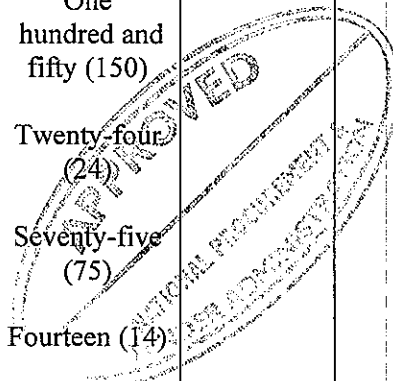

Goods and Related Services (Valued G\$15M and above)

- Ovaley Bolt 5/8" 18" long	Eighty-four (84)			
- Washer 3/4" Curved Galvanized	Fourteen (14)			
- Washer 5/8" Curved Galvanized	One hundred and forty-four (144)			
- Washer 5/8" Square Galvanized	Four hundred and twenty-one (421)			
- Washer 3/8" Round Galvanized	One hundred and fifty (150)			
- Tree trimming & Vegetation clearance	SUM			
- Transportation and Labour	SUM			
Test and commission completed overhead distribution network after construction.	SUM			

Please note that the procuring entity will not be responsible for customs clearance of the goods.

Duly authorized to sign for and on behalf of

_____ (name of Bidder)

_____ (Full name)

_____ (Title)

_____ (Signature and seal)

SUPPLY CONTRACT FOR GOODS

THIS CONTRACT made the _____ day of _____ 202__ between *Guyana Energy Agency* (hereinafter referred to as "the Procuring Entity"), on the one hand, and _____ [*name of Supplier*] from _____ [*city and country of Supplier*] (hereinafter referred to as "the Supplier"), on the other hand have come to an Agreement on the following:

The Procuring Entity has announced bid for procurement of goods and services, namely ***Design, Supply, Installation and Commissioning of an 88.6 kWp Off-Grid Solar Photovoltaic Micro-Grid System and Electrical Distribution in Sebai*** and has accepted the Supplier's bid for the supply of indicated goods and services to the sum of _____ [*Contract Price in words and figures*] (hereinafter referred to as "the Contract Price").

THIS CONTRACT WITNESSES AS FOLLOWS:

1. In this Contract, the terms and expressions have the same meanings as are respectively assigned to them in the Conditions of Contract referred to.
2. The following documents shall form the Contract and shall be deemed its integral part, viz.:
 - (a) Procuring Entity's Notification of Award;
 - (b) Bid and Price Schedule submitted by Bidder;
 - (c) Schedule of Requirements;
 - (d) Technical Specifications;
 - (e) General Conditions of Contract;
 - (f) Special Conditions of Contract;
 - (g) Other documents included in the Contract documents;
3. This Contract shall prevail over all other Contract documents. In the event of any discrepancy or inconsistency within the Contract documents, then the documents shall prevail in the order listed above.
4. In consideration of the payments to be made by the Procuring Entity to the Supplier as hereinafter mentioned, the Supplier hereby covenants with the Procuring Entity to provide the Goods and Services, and remedy defects therein in conformity in all respects with the provisions of the Contract.
5. The Procuring Entity hereby agrees to pay the Supplier in consideration of the delivery of the Goods and Services and the remedying of defects therein, the Contract Price or such other sum as may become payable under the provisions of the Contract at the times and in the manner prescribed by the Contract.

IN WITNESS of the aforesaid, the parties hereto have caused this Contract to be executed in accordance with the legislation of Guyana the day and year first above written in the beginning of the document.

Signed and Sealed _____ [*Full name and title of Procuring Entity's representative*]

Signed and Sealed _____ [*Full name and title of Supplier's representative*]

Manufacturer's Authorization

The Bidder shall require the Manufacturer to fill in this Form in accordance with the instructions indicated. This letter of authorization should be on the letterhead of the Manufacturer and should be signed by a person with the proper authority to sign documents that are binding on the Manufacturer. The Bidder shall include it in its bid, if so indicated in the BDS.]

Date of Bid Submission (day/ month/ year):	
IFB No.: [insert number of bidding process]	
Alternative No.: [insert identification No if this is a Bid for an alternative]	

To: _____ [insert complete name of Purchaser]

WHEREAS

We _____ [insert complete name of Manufacturer], who are official manufacturers of _____ [insert type of goods manufactured], having factories at _____ [insert full address of Manufacturer's factories], do hereby authorize _____ [insert complete name of Bidder] to submit a bid the purpose of which is to provide the following Goods, manufactured by us _____ [insert name and or brief description of the Goods], and to subsequently negotiate and sign the Contract.

We hereby extend our full guarantee and warranty in accordance with Clause 1.3 of the General Conditions of Contract, with respect to the Goods offered by the above firm.

Signed: _____ [insert signature(s) of authorized representative(s) of the Manufacturer]

Name: _____ [insert complete name(s) of authorized representative(s) of the Manufacturer]

Title: _____ [insert title]

Duly authorized to sign this Authorization on behalf of: _____ [insert complete name of Bidder]

Dated on _____ day of _____, _____ [insert date of signing]

**PERFORMANCE SECURITY
(Bank Guarantee or Insurance Bond)**

TO: _____
[Name of Procuring Entity]

WHEREAS _____ [name of the Supplier] (hereinafter called "the Supplier") has undertaken, in accordance with the Contract No. _____ [Contract number] dated _____ 202__ to **Design, Supply, Install and Commission an 88.6 kWp Off-Grid Solar Photovoltaic Micro-Grid System and Electrical Distribution Network in Sebai** (hereinafter called "the Contract"),

AND WHEREAS it has been stipulated by you in the said Contract that the Supplier shall furnish you with a Bank Guarantee or Performance Bond from an Insurance company licensed by the Bank of Guyana, to the sum specified therein as a security for compliance with the Supplier's obligations under the Contract,

AND WHEREAS we have agreed to furnish the Supplier with a security,

THEREFORE WE hereby confirm that we are the Guarantors and are responsible to you on behalf of the Supplier, up to a total of _____ (amount of security in words and figures) and, we undertake to pay you, on your first request notifying of the Contractor's default with the Contract, and without cavil or argument, any sum or sums within the above limits, as aforesaid, without your needing to show grounds or reasons of your request or the sum specified therein.

Any modification or addition, or amendment in the terms of Contract which may be made by the Procuring Entity and the Supplier by Additional Agreement shall in no way release us from obligations under the Guarantee, and we waive any notice of modification, addition, or amendment. This guarantee shall be valid until full completion of the Contract Conditions by the Supplier. Also, we confirm that the license issued to the Bank shall provide for activity on issuance of a bank guarantee, and the person signing the guarantee is entitled to act on behalf of the Bank, and if the approval of Board of Directors or of General Stockholders Meeting is required, it is already received, and there is no other approval required

This guarantee shall be valid till the _____ day of _____ 202__.

(Full name of Bank / Surety's representative) (Title) (signature and seal)

Dated on _____ day of _____ 202__.

Address of the Bank issuing guarantee:

Letter of Acceptance
(Letterhead paper of Procuring Entity)

_____ (date)

To: _____

(Name of Supplier)

(address of Supplier)

We hereby notify you that your bid dated the ____ day of _____ 202__, for the supply of goods _____ (*description of goods*) up to a total of _____

(amount in figures and words)

as amended and modified in accordance with the Instructions to Bidders is hereby accepted by our agency.

Simultaneously, we send you the Form of Contract and request you, pursuant to Clause 20.1 of the Instructions to Bidders, during seven (7) days to sign and date the Form of Contract and return it at our address. Jointly with the signed Contract, we request you to furnish the performance security, in accordance with ITB Clause 20.2.

You hereby entrusted to start supply of the Goods, in accordance with the terms and conditions of a Contract.

Name of Agency

Full name and Title

Signature of Authorized Representative

Annex: The Contract

Affidavit of Authorization

TO: _____ [name of Procuring Entity]

WHEREAS _____ [name of Supplier],
who is the Supplier _____ [name and/or description of goods].

do hereby authorize _____ [name and address of
Supplier's Representative] to submit the Bid, and sign the Contract based on Invitation for Bids for the
abovementioned goods to be supplied by us, and

[Full name, title, signature for and on behalf of Supplier]

Dated on « _____ » day of _____ 202____. (seal)
(date)

Note: The affidavit of authorization must be drafted on a letterhead of the Supplier and signed by a Commissioner of Oats to Affidavit or Justice of the peace. The Bidder shall include this authorization in their Bid.

EVALUATION AND QUALIFICATION CRITERIA

NO.	DESCRIPTION	PASS/FAIL
1.	Submission of a valid business registration or certificate of incorporation that is clearly legible . Incorporated companies must submit a list of directors.	
2.	Submission of a valid NIS compliance certificate in the name of the business as per business registration. Document must be clearly legible.	
3.	Submission of a valid GRA compliance certificate in the name of the business as per business registration. Document must be clearly legible.	
4.	Completed and signed supplier's bid form (page 48)	
5.	Completed and signed price schedule must be submitted.	
6.	Completed and signed delivery schedule (page 20) or statement of agreement to supply goods/services within the period specified by the Procuring Entity in the delivery schedule.	
7.	Provision of documentation detailing the technical specifications for the items listed in the Schedule of Requirement (page 20) or evidence to show that the goods match the requirements of the items listed in the Technical Specifications (page 22).	
8.	Submission of bid security in the amount of 2% of the bid price in the form of a bond from an Insurance company licensed by the Bank of Guyana or a bank guarantee or manager's cheque.	
9.	Demonstrate experience and technical capacity by providing documentary evidence that shows the completion of a minimum of two (2) contracts of similar size and scope to the Project over the last two (2) years. Bidder must provide copies of contracts with previous clients. Bidder must also demonstrate the experience of completing contracts of a minimum value of \$4,000,000 for each year over two (2) years.	
10.	Evidence of financial capacity, in the name of the bidder, representing 30% of the bid price. Financial Capacity must be evidence in the form of a bank statement or Line of credit from a bank or Insurance company licensed by the Bank of Guyana. The line of credit must state a figure. The document must be dated within one month of the bid opening date and be clearly legible . When a photocopy is presented, it must be certified a 'true copy of original' by the issuing company	
11.	Bidder must provide a letter of Authorization for the Procuring Entity to seek reference from the bidder's Bank/financial institution relating to the financial capacity evidence supplied. The document must be dated within one month of the bid opening date and be clearly legible.	
12.	Written confirmation of authorizing signatory must be provided. This must be in the form of an Affidavit of Authorization endorsed by a Commissioner of Oaths or Justice of Peace.	
13.	Bidder must provide audited financial statements for the past three years for incorporated companies. Financial statements must be audited by a Chartered accountant/accountancy firm and include an auditor's note.	

	<p>OR</p> <p>Registered businesses must provide Balance Sheets, Profit and Loss Accounts, and Income and Expenditure Accounts for the past three years. These financial statements must be approved by a Chartered accountant/accountancy firm. The financial analysis would include: Current ratio: >1 for each year of the last 3 years; Net worth: +ve and minimum of 20% of bid value; Average annual turnover: GYD 4million.</p>	
14.	<p>The Bidder shall provide accurate information on the related bidding form as provided on page 69 about any litigation or arbitration resulting from contracts completed or on-going under its execution over the last five years.</p> <p>Pending Litigation: All pending litigation shall in total not represent more 50% of the Bidder's net worth and shall be treated as resolved against the bidder. If bidder has pending litigation representing more than the stated percentage, the bid will not be considered.</p> <p>Litigation History: Non-performance of a contract did not occur as result of supplier's default since 1st January, 2018. If bidder has a history of nonperforming contract the bid will not be considered.</p>	
15.	<p>Bidder must provide a letter stating any or no terminated or abandonment of projects. The letter must be dated within one month of the bid opening date.</p>	
	<p>Technical Requirements</p>	
16.	<p>Photovoltaic Modules</p> <ul style="list-style-type: none"> • PV Modules are according to International Standards IEC 61215, IEC 61730, IEC 61701, IEC 62804, UL1703 etc.) and the National Electrical Code 2017 Article 690; • 300 watts or greater rated solar modules totaling 88.6kWp • All modules should be made of crystalline silicon solar cells with conversion efficiency not less than 19.5% at standard test conditions • All PV modules shall show the same capacity • The Manufacturer should be internationally recognised and provide references and certificates on module testing. • MC4 connectors for all Modules • 20-years warranty on Modules 	
17.	<p>Mounting Structure for PV Modules</p> <ul style="list-style-type: none"> • Meets required technical specifications. 	
18.	<p>Solar Photovoltaic Inverters</p> <ul style="list-style-type: none"> • The minimum size of each Inverter shall be 10 kW or above and totaling between 90% and 100% the solar array name plate capacity • Master/Slave or String type • AC Grid Frequency – 60 Hz • Operating Frequency range: Frequency Range ≥ 58.4 to ≤ 61.7 (Field Selectable) • Certificates and Compliance with International Standards Including 	

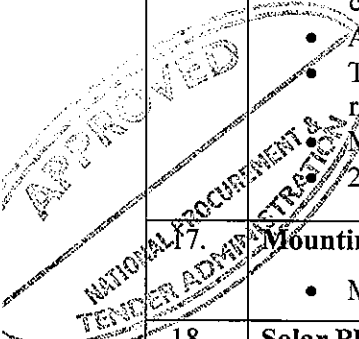

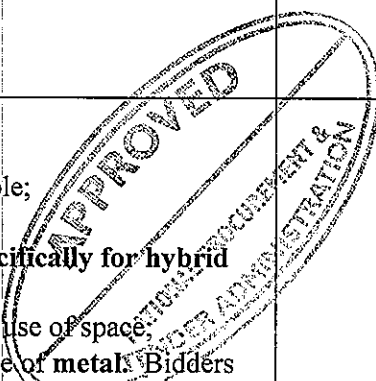
	<p>(UL 1741-2010, UL 1699B, IEEE 1547-2003, IEEE 1547.1-2003, ANSI/IEEE C62.41, FCC Part 15 A & B)</p> <ul style="list-style-type: none"> • Pure Sinewave output; • High efficiency (AC) > 90% @ P/Pn (AC) = 10%; • Protection against overcurrent and overvoltage; • Indications of status of operation (e.g. LED); • Automatic disconnect from the grid in case of need • Capability of connecting monitoring devices; • Ground fault monitoring / grid monitoring. • Safety measures (EN 61000, EN 60950 and others). • Interface to the main grid (switchboard including manual disconnection device). • 10 Years warranty 	
<p>19.</p>	<p>Hybrid Inverter</p> <ul style="list-style-type: none"> • Capacity totaling between 90 – 120% of PV inverters • Master/ Slave or String Type; • Maximum efficiency of 96% with 94.5% CEC efficiency; • Intelligent battery management including state of charge calculation for maximum battery life; • Integrated soft start/generator support; • Versatile - complete for off-grid management as well as grid-tie battery backup/AC Coupling; • Suitable for systems from up 100 kW; • Excellent overload characteristics with active temperature management; • Certification UL 1741 / UL 1998; • Modular, stackable design; • Nominal Frequency 60 Hz; • Frequency Range ≥ 58.4 to ≤ 61.7 (Field Selectable); • Pure Sine Wave; • Automatically transfers between inverter power and incoming AC power source; • Compatible battery types Flooded, Gel, AGM, LiON; • Indications of status of operation (e.g., LED); • Over voltage and under voltage protection; • Over-temperature protection; • Overload protection; • Short circuit protection. • Five-Year Standard Warranty; 	
<p>20.</p>	<p>Energy Storage System (Lithium Technology)</p> <ul style="list-style-type: none"> • Minimum Energy Storage capacity of 290 kWh • Batteries should be deep cycle type and rechargeable; • Lithium Ion/Iron technology; • Designed for renewable energy applications specifically for hybrid application; • Batteries are to be placed on racks to minimize the use of space; • Bidders are to supply the racks which must be made of metal. Bidders are to supply the racks which are to be fully fabricated from metal and resistant to rust. Racks should be made to minimize the space required to store the batteries and allowance for effective 	

	<p>ventilation. Welding, bolts and nuts used must be resistant to rust. Racks must be painted in two coats with anti-rust protective layer paint. The preferred colour would be black. The battery racks MUST be adequately grounded.</p> <ul style="list-style-type: none"> • Bidders are to supply drawings of the racks with battery bank configuration; • Minimum battery size is 300 Amp-Hour; C10 • Sealed maintenance free; • Manufacturer's data sheets containing battery performance specifications must be provided. Batteries must be procured from same make (manufacturer) having same ampere-Hour and voltage rating; • 4,000 and above cycles at 80% depth of discharge • Standards to be conformed to: <ul style="list-style-type: none"> • UL 1989 • IEC 61427:1999 • UL 2054 • Manufacturing process must have conformed to environmental management standard ISO 14001. • 6 Years warranty on batteries 	
21.	<p>Cables</p> <ul style="list-style-type: none"> • Meets required technical specifications. 	
22.	<p>Monitoring System</p> <p>The installation shall provide real-time web-based electric energy meter, power Meter, data logger and appropriate current transformers to record electric consumption of the village from the grid and solar energy produced by the solar PV system and also provide a combined recording of all inverters/circuits loads. It should provide:</p> <ul style="list-style-type: none"> • Graphical and Numerical real-time energy information and long-term reports (total power demand of the building including from the utility and solar, total energy consumption of the building from the utility and solar, total power generated by the solar system, total energy produced by the solar system, net energy, avoided carbon dioxide emissions); • Historic Data; • Data export via push or pull with an open data API. • No service contracts • Warranty 3 years • Must have at least one (1) ethernet styled registered jack (RJ) 45 data port. 	
23.	<p>Charge Controller</p> <ul style="list-style-type: none"> • Charge controller must be rated 25 % over system capacity size • Nominal Battery voltage: 12/24/48 V • Maximum Power Point Tracking (MPPT) charging technology • Charge regulation method: Three stage (bulk, absorption, float) plus manual equalization • Available monitoring and configuration • Supported battery types: Flooded, GEL, AGM, Custom • Compatible with any brand of PV module, any grounding method • Stand-alone application or integration with inverter charger system 	

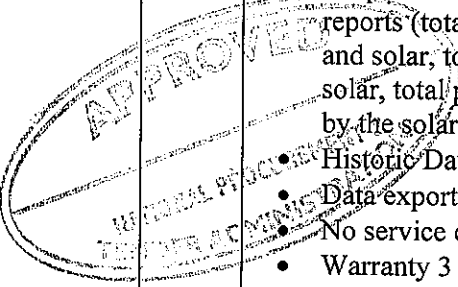

	<ul style="list-style-type: none"> • Certification: UL1741, CSA 107.1, EN 50178/IEC 62477-1 • 5 years Warranty 	
24.	Pad Mounted Transformer <ul style="list-style-type: none"> • Meets technical specifications outlined 	
25.	Pole Mounted Transformers <ul style="list-style-type: none"> • Meets technical specifications outlined 	
26.	Rural Cutouts <ul style="list-style-type: none"> • Meets technical specifications outlined 	
27.	Lightning Arrestors <ul style="list-style-type: none"> • Meets technical specifications outlined 	
28.	Design Diagram <ul style="list-style-type: none"> • Provide detailed schematic design layout of the proposed installation including all interconnections of the complete system; explanatory notes for sizing of equipment and components that comprise the system, and energy production calculations. • Design complies to NEC 2017 Articles 690 and 705 	
29.	Installation <ul style="list-style-type: none"> • All installations are to be conducted in accordance with NEC 690 requirements, which cover installation, protection, and grounding of solar PV systems. • Grid interconnection requirements are met • Earthing system requirements are met • Monitoring system connection to existing network of facility. • Hybrid inverter circuit breaker requirement met. • All works must be in accordance with the NESC and confirm to standard overhead line construction guidelines and practices. 	
30.	Product Manual and Label for each equipment are provided <ul style="list-style-type: none"> • Voltage / wattage/ current • Model number • Serial number • Certification • Manufacturer's brand 	
31.	Provide statement on availability of spare parts from purchaser's country	
32.	Provision of valid manufacturer's authorization or authorized distributor letter	
33.	Provision of a signed statement of warranty and/or guarantee for applicable items. At least three (3) years warranty on complete system is required.	
34.	Warranty: Two types of warranty have to be offered by the Bidder: <ol style="list-style-type: none"> 1. Warranty on hardware failures on all products offered and used according to international established terms (3 years minimum) 2. Warranty on the proper operation of the provided equipment according to the specification and terms fixed in the contract between the Seller and the Procuring Entity (3 years minimum) 	
35.	Bidder must provide a statement for the availability of spare parts and/or after sales services. Bidders statement indicating its acceptance or otherwise in offering Local after sales service of no less than three (3) years. Bidder must state the nature of service that will be provided.	
36.	Submission of an implementation schedule indicating important milestones such	

	as equipment delivery to site, installation, testing and commissioning of system. Frequent progress reports and work plan are to be provided to the Procuring Entity as required by the procuring entity during project execution.	
--	--	--

Award of contract

The contract will be awarded to the Bidder who is substantially responsive to the bid document and who has offered the lowest bid price.

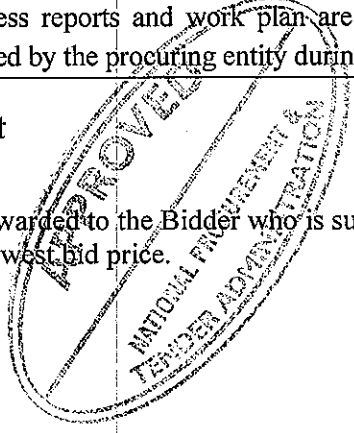

Pending Litigation Format				
<input type="checkbox"/> No pending litigation in accordance with Evaluation Criteria # 14				
Year of dispute	Amount in dispute (currency)	Outcome as Percentage of Net Worth	Contract Identification	Total Contract Amount (current value, currency, exchange rate and USD equivalent)
[insert year]	[insert amount]	[insert percentage]	<ul style="list-style-type: none"> Contract Identification: [indicate complete contract name, number, and any other identification] Name of Purchaser: [insert full name] Address of Purchaser: [insert street/ city/ country] Matter in dispute: [indicate main issues in dispute] Status of dispute: [indicate if it is being treated under Arbitration or being dealt with by the Judiciary] 	[insert amount]

Litigation History

Litigation History Format		
<input type="checkbox"/> No court/arbitral award decisions against the Bidder since 1 st January 2018, in accordance with Evaluation Criteria # 14		
Year of award	Contract Identification	Total Contract Amount (current value, currency, exchange rate and USD equivalent)
[insert year]	<ul style="list-style-type: none"> Contract Identification: [indicate complete Contract name, number, and any other identification] Name of Purchaser: [insert full name] Address of Purchaser: [insert street/city/country] Matter in dispute: [indicate main issues in dispute] Party who initiated the dispute: [indicate "Purchaser" or "Supplier"] Status of dispute: [indicate if it is being treated by under Arbitration or being dealt with by the Judiciary] 	[insert amount]